

**214-911**

## **DGUV Information 214-911**



# **Safe operations of helicopters during aerial work**

**komm****mit****mensch** is the national campaign of the German Social Accident Insurance (DGUV). Its purpose is to support companies and educational institutions in developing a culture of prevention in which all action is underpinned by safety and health. Further information at [www.kommmitmensch.de](http://www.kommmitmensch.de)

---

## Imprint

### Editor:

Deutsche Gesetzliche  
Unfallversicherung e.V. (DGUV)

Glinkastraße 40  
10117 Berlin  
Telephone: +49 30 13001-0  
Fax: +49 30 13001-9876  
E-Mail: [info@dguv.de](mailto:info@dguv.de)  
Internet: [www.dguv.de](http://www.dguv.de)

Subject area Aeronautics of the  
Specialist area Traffic and Landscape of the DGUV

Authors: Stephan Elfert (BG Verkehr),  
Enrico Ragoni (AirWork & Heliseilerei GmbH)

German edition: September 2017, English version issued September 2020

DGUV Information 214-911 can be obtained from your competent German Social Accident Insurance Institution or at [www.dguv.de/publikationen](http://www.dguv.de/publikationen)

# **Safe operations of helicopters during aerial work**

# Table of Contents

	Page
<b>Preliminary remarks</b> .....	<b>6</b>
<b>1 Scope of application</b> .....	<b>7</b>
<b>2 Terms and Definitions</b> .....	<b>8</b>
<b>3 Fundamental requirements for ensuring aviation and occupational safety</b> .....	<b>13</b>
3.1 General employer's and insured individuals' duties .....	13
3.2 Operational organisation of aviation and occupational safety .....	15
3.3 Briefings and operating procedures .....	18
3.4 Operational and final briefings .....	19
3.5 Qualification of assignment personnel .....	20
3.6 Personal Protective Equipment (PPE) .....	22
3.7 Occupational medical prophylaxis .....	25
3.8 Inspection of work equipment and Personal Protective Equipment .....	25
3.9 Communication .....	26
<b>4 Provision and procurement of working materials for use with helicopters</b> .....	<b>28</b>
4.1 General requirements .....	28
4.2 Demands on helicopters and their equipment .....	28
4.3 Requirements for Load Lifting Devices (LLD) .....	31
4.4 Other working materials .....	47
<b>5 Setting up outside working stations and flight routes</b> .....	<b>48</b>
5.1 General requirements .....	48
5.2 Load pick-up and load drop-off places .....	49
5.3 Jettisoning and emergency landing places .....	49
5.4 Refueling places .....	49

	Page
<b>6 Assignment-specific measures</b> .....	<b>50</b>
6.1 Refueling helicopters .....	50
6.2 Luggage and internal cargo .....	59
6.3 External cargo and installation flights .....	60
6.4 Flights with bulk goods .....	63
6.5 Flights with spray media .....	65
6.6 Inspection flights on overhead power lines and pipelines .....	67
6.7 Measuring flights .....	68
6.8 Fire-fighting/forest fire-fighting flights .....	69
6.9 Photo and film flights .....	70
 <b>Annex 1</b>	
Information on the execution of risk assessments .....	71
 <b>Annex 2</b>	
Determining of external load forces .....	80
 <b>Annex 3</b>	
Attaching of external loads .....	86
 <b>Annex 4</b>	
Instructions and briefings .....	105
 <b>Annex 5</b>	
Means of communication .....	111
 <b>Annex 6</b>	
Information on setting up outside working stations .....	120
 <b>7 References</b> .....	<b>124</b>

# Preliminary remarks

Helicopter operations of the aerial work category are processes that contain high risks due to the operating conditions. They are an example for the interaction of complicated technology with high mechanical drive performance and manpower in a very confined space.

In case of necessity, for example, the statutory minimum flight heights, the necessary safety heights for an auto-rotation or the safe distances from obstacles are undershot. With various types of work the helicopter may briefly be in a "confined area" situation and the ground personnel are also exposed to a variety of special risks at load pick-up, setting down or assembly points.

Carrying out such work demands professional guidance and management of everyone involved. Work assignments can only be carried out safely by a thorough risk assessment, full use of all possibilities to minimise risks, a targeted choice of appropriate working materials and personnel as well as comprehensive training of the former.

This information gives the employers of aviation companies with the field of application helicopters instructions and recommendations regarding technical, organisational and personnel measures to implement their duties from the statutory occupational safety and health protection regulations or accident prevention regulations. It shows ways of effectively avoiding or minimising accidents at work, occupational diseases and work-related health hazards.

# 1 Scope of application

This information is applicable to industrial operations with helicopters in the category “aerial work”.

It is also to be applied to commercial operations of police or military armed forces.

## 2 Terms and Definitions

**2.1 Helicopter operations** as defined in this information are business operations of helicopters for the application purpose (category) “aerial work”. The operations are designated as “occasional traffic” (see Section 22 Air Traffic Act). These include especially:

- photography and filming
- agricultural operations
- installation flights
- timber transporting (logging)
- measuring flights
- flights with working basket
- flights with persons outboard
- banner towing
- monitoring tasks
- flights with fixed working seat in or on the helicopter
- snowfield blasting
- fire-fighting operations

**2.2 Working materials** are tools, devices, machines or systems, such as, for example:

- helicopters
- ground support equipment for the helicopter
- Load Lifting Devices
- transport and loading vehicles
- tools
- means of communication

**2.3 Load Lifting Devices** are mounted between the helicopter’s primary cargo hook and the load, to enable their lifting. These include for example:

- lifting rope systems with fittings
- slinging equipments and their components
- shock absorbers
- swivels
- remote cargo hooks



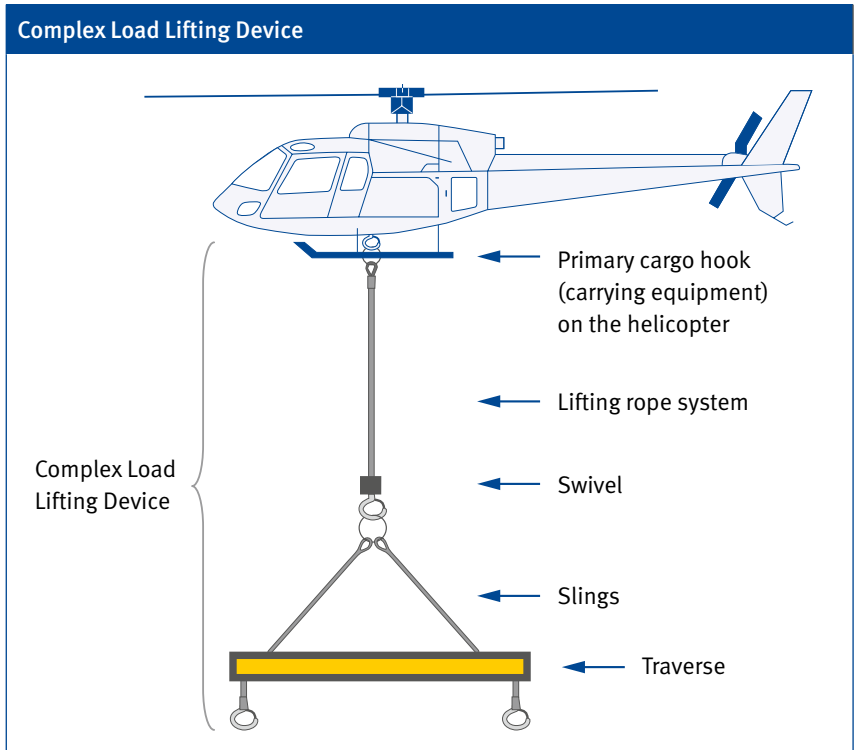

The following can again be attached to Load Lifting Devices, e.g.:

- power-driven concrete buckets
- traverses
- special lifting lugs
- ready-to-use chains and their components
- FIBC (Flexible Intermediate Bulk Container, “Big Bag”)

**2.4 Slinging equipments** are used to fasten (attach) the load and are normally attached in the secondary cargo hook using appropriate swivels. Slinging equipments and their components are classified as Load Lifting Devices. The following are used as slinging equipments:

- slinging ropes
- lifting straps
- round slinging equipments
- sling chains
- multiple leg suspension gear (2-, 3- or 4-leg)
- detachable connecting parts (e.g. shackles, round sling hooks)
- short choker steel ropes for logging

**2.5 Primary cargo hooks** on the helicopter are connected to the helicopter and used to accept Load Lifting Devices or a direct load (e.g. fire extinguishing water containers – Bambi Bucket). The permitted load capacity of the primary cargo hook (Working Load Limit, WLL) is one of the limiting features of a helicopter.

**2.6 Lifting rope system** is the part of the Load Lifting Devices that is used between primary cargo hook and load or slinging equipments.

**2.7 Personnel Carrying Device Systems** (PCDS) are devices or (carrying) systems with structural features that are required for the transport of persons as external loads on the helicopter (Human External Cargo, HEC) in the context of operations. These are, in particular:

- working cages,
- platforms and
- rope systems with Personal Protective Equipment against falling for persons with and without working seats.

**2.8 Technical fittings** of the helicopter are working fixtures and fittings in or on the helicopter that are necessary for the execution of the respective types of operation and equipped with a Supplementary Type Certificate (STC). These include, e.g.:

- primary cargo hook
- attachment points on the skid bases
- load cell with indication
- facilities to observe the external cargo, such as for example:
  - cameras
  - mirrors
  - bubbles

**2.9 Other working materials** are necessary working materials for the respective type of assignment without load-bearing function, such as, for example:

- lashing belts
- holding and guiding ropes
- hook clamps
- packaging film
- assembly aids

**2.10 Employer** is the respective natural or legal person, where the economic outcome of the company turns out to be immediately to his advantage or disadvantage.

**2.11 A Responsible Person** can be entrusted with the management of a sector of the company or within the scope of the tasks and powers assigned to him for a helicopter operation by the employer.

**2.12 Insured individuals** as defined in this information are all persons, who enjoy the protection of the statutory accident insurance.

- 2.13** A **Head of Operations** is a person, who is entrusted by the employer to manage the respective working operation within the scope of the tasks and powers assigned to him/her.
- 2.14** A **Marshaller** is a trained person with special tasks on board or on the ground within the scope of the respective type of task of the aerial work.
- 2.15** **OSH Professional (OSH = Occupational Safety and Health)** is a person with proven safety-related specialist knowledge appointed in writing to advise the employer.
- 2.16** An **Occupational Physician** is a person with proven occupational medical specialist knowledge appointed in writing to advise the employer.
- 2.17** **Outside working stations** are permanent or temporary, portable places of work for work operations, such as, for example:
- external take-off and external landing places
  - load pick-up and load drop-off places
  - refueling places
  - jettisoning and emergency landing places

# 3 Fundamental requirements for ensuring aviation and occupational safety

## 3.1 General employer's and insured individuals' duties

The employer's task is to take the required measures to prevent work accidents, occupational diseases and work-related health risks and to ensure effective first aid.

This generally formulated task from occupational safety and health legislation must be extended by the aviation law sector in airline companies, so that the relationship results in

**Safety during aerial work = Occupational safety + Aviation safety.**

Every employer, even a foreign employer, who works with employees in Germany, must take all the necessary measures to ensure safety in the company. Measures are necessary, if a risk can be minimised by these and if the resources and expenses to be deployed are proportionate to the size of the company.

If an employer sends his insured individuals abroad, in order to work there, he must check to what extent the German governmental occupational safety and health regulations and regulations of the German Social Accident Insurance (DGUV) are applicable.

An absolutely necessary means of doing so is the **risk assessment** – a process for determining risks and for assessing the associated risks for the employees.

**The result is the prerequisite for taking effective and operational occupational safety and health protection measures, which are to be taken according to the following principles:**

- Risk to life and health is to be avoided as far as possible or effectively minimised.

- The state of the art of technology, occupational medicine and hygiene as well as other substantiated findings of occupational research are to be taken into account in the case of the measures to be taken.

Here, technical measures have priority over organisational or personnel measures.

**The risk assessment consists of:**

- a systematic determination and assessment of relevant hazards and
- the derivation of corresponding measures.

**To plan and execute the necessary measures:**

- suitable chains of command are to be formed
- instructions are to be issued and compliance with them is to be checked
- the insured individuals are to be qualified by training and briefing
- the Occupational Physician, the OSH Professional and, if present, Safety Delegates are to be involved for support

For airline companies legal regulations to ensure **aviation safety** (aviation law) also apply. It is the task of an operational command and organisation system to observe both components of the “safety in the company” and to introduce necessary changes.

Insured individuals are obliged to support all measures serving occupational safety and health protection and to ensure their safety according to their possibilities and the employer’s instructions. At the same time, they have to make sure that the safety and health of persons, who could be affected by their actions or neglect, are not impaired.

The insured individuals have to follow the employer’s instructions during their work.

Instruction in the field of occupational safety and health protection is defined as the request to behave in a safety-conscious manner in a specific

way or a concrete situation. Before transferring the work task to the insured individual, the employer must check that this person is in a position to comply with the demands and regulations on occupational safety and health protection in accordance with his mental and physical abilities, skills and characteristics. If the employer is himself not in a position to give an objective evaluation of the competence or aptitude of the insured individual, he must seek advice from suitable persons. This may be the competent Occupational Physician for example.

**Exception:** Instructions that are clearly contrary to safety and health requirements must not be obeyed by the insured individuals.

### 3.2 Operational organisation of aviation and occupational safety

Depending on the size of the company and taking all relevant factors into account (e.g. varying types of use and locations, the result of the risk assessment) the employer may come to realise that he is unable to meet his obligation to ensure safety in the company on his own. Suitable persons are then necessarily to be used as operational managers.

These must be reliable and qualified persons, who are entrusted with this task in writing.

With their management function they take on the necessary tasks and duties of the employer, whereby the employer's responsibility is not transferred in doing so. As a rule, the operational procedure is divided here into processes and subject areas and the corresponding management functions formulated. The managers deployed are granted an autonomous power to take decisions within the framework of transferred powers and competences.

An appointment can also be limited in time or take place for one or more work assignments. It is important that a seamless distribution of the areas

of responsibility and a binding and clear demarcation of competency is always made.

According to the accident prevention regulation “Occupational Physicians and occupational safety specialists” (DGUV Regulation 2) **Occupational Physicians** and **OSH Professionals** are to be appointed in writing for the company.

These must advise the employer and his managers in particular in all matters of occupational safety and health protection and humane working conditions.

**In doing so, the following should be achieved:**

- the regulations serving occupational safety and health and accident prevention are applied according to the special operating conditions,
- improvements in occupational safety and health and accident prevention can be implemented,
- the measures serving occupational safety and health and accident prevention achieve the highest possible degree of efficiency.

Occupational Physicians and OSH Professionals can belong to the company or offer their supervision services externally to the employer.

To organise effective **first aid** the employer has to make all the necessary facilities and material resources as well as the staff needed for the general operational procedure but also for special work assignments. Within the scope of his duty of care, it is up to him to ensure at all times that trained staff and first aid materials are on site to take optimum primary care of injured persons.

In companies with regularly more than 20 employees, and taking into account the existing accident and health risks for the employees, the employer has to appoint **Safety Delegates** in writing. The appointment is also appropriate in the event of a smaller number of employees in



accordance with the risk and relevant accident situation and/or the work and organisational structure of a company.

**The Safety Delegates' tasks include:**

- supporting the respective managers in the execution of measures to prevent accidents at work, occupational illnesses and work-related health hazards
- ensuring the presence and proper use of the Personal Protective Equipment
- ensuring the presence of the necessary protection systems
- drawing the attention of insured individuals to accident and health risks
- reporting safety-related defects to the superior
- taking part in site inspections and examinations on accidents and occupational diseases

Safety Delegates in companies do not exercise their duties full-time, but only in addition to their actual role. They do not bear any responsibility regarding this function.

The employer must allocate the Safety Delegate adequate time to exercise his activity according to the operational conditions. In order for the activity to be characterised by sustainability, the employee should be given the opportunity of training and regular further training, e.g. by seminars held by the trade association.

The employer has to designate a suitable **Head of Operations** so that work assignments can be planned, coordinated and safely executed. His duties in the field of occupational safety and health protection are to be transferred to him in writing. Under certain circumstances the helicopter pilot can also take on this task for the work assignment to be carried out.

If employees from several companies are working in one work place (e.g. on load lifting, depositing or assembly points) and if the activities of one of these companies could affect the employees of another company

due to the spatial and temporal proximity, the employers have to collaborate accordingly and coordinate the necessary measures of occupational safety and health protection before the work assignment commences (coordination of work). If it is necessary to avoid a mutual hazard, the Head of Operations should also be named as coordinator, to synchronise the work.

If special risks are present, the coordinator is to be given the power to give instructions. As this can concern instructions to be given to employees of other companies, the power to give instructions should be agreed expeditiously between the employers in the form of a contract.

### **3.3 Briefings and operating procedures**

A briefing is an employer's explanation and instruction relating to the concrete work place or area of responsibility for safety-conscious behaviour of the employees. It must be adapted to the concrete, individual work and activity situation and be oriented to the results of the risk assessment. During working hours employees must be instructed appropriately and, relating to the work task and their own qualification, sufficiently.

The briefing has to take place at least once a year and, in addition, before starting an activity and is to be documented.

If there is a case of personnel leasing, the hiring company is bound to carry out operational or assignment-specific briefing. Other occupational safety and health duties of the supplier as employer, in particular, the general briefing obligation, remain unaffected.

The preparation of concrete operating procedures is also the employer's responsibility.

He/she, in particular, has to prepare concrete instructions and guidelines in uniform form and design for the operation of machinery, dealing with

dangerous substances or for special activities. Assignments with helicopters also count as special activities. The employees are to be briefed e.g. on the basis of written operating procedures, about the hazards, the measures of occupational safety and health protection, about possible malfunctions and the existing experiences in using the working material in a comprehensive manner and language.

### 3.4 Operational and final briefings

An operational briefing is to be carried out before each assignment and a final briefing after assignments involving all those involved under the leadership of the Head of Operations. In the case of recurrent, same work assignments, as a rule an operational briefing and a final briefing before and after each working shift is sufficient.

**Content and duration of the discussions depend on the respective operation. They include at least the following topics:**

- what work is to be carried out (e.g. order description)
- areas of responsibility/competences of the persons involved
- local conditions (e.g. organisation place, load pick-up and load drop-off place, possible escape routes)
- temporal procedure of the assignment, work organisation, working procedure and communication
- execution of the respective work task, including the safe use of all working materials and equipment
- general codes of conduct, e.g. upon recognising safety-related deficiencies
- agreement on clear communication
- behaviour in case of emergencies or in dangerous situations
- assignment-specific particularities

In particular, anomalies or organisational deficits of the work assignment carried out are addressed in the context of the final discussion.

At the same time, proposals for avoiding such deficiencies and offensive communication in future have to be agreed upon.

### 3.5 Qualification of assignment personnel

When transferring work tasks to insured individuals the employer has to take into account, whether the corresponding person is qualified for completing the actual task and is thus able to comply with the provisions and measures of occupational safety and health protection.

The employer must convince himself of the aptitude and reliability of the employees within the framework of the applicable regulations.

While the reliability refers to the personal characteristics of the employees and so cannot always be judged objectively by the employer, the required aptitude refers to objectively technical and, where necessary, also to health evaluation criteria.

**The following technical evaluation criteria are applied:**

#### **Demands on the qualification of the helicopter pilots**

Helicopter pilots must have all the prescribed authorisations according to aviation law.

#### **Requirements for the qualification of the Marshalls**

**Marshalls must have sufficient knowledge, depending on employer-specific rules, the corresponding work organisation and the respective helicopter assignments, of at least:**

- slinging techniques
- Load Lifting Devices
- devices and facilities
- communication (internal and external)
- danger zones

- planned flight activities
- hazards from aircraft
- hazards from operating materials
- handling of fire-fighting facilities
- first aid (initial measures at the site of the accident)

In addition, knowledge of dealing with aircraft fuel is required for work in the field of refueling aircraft, of the actual refueling process including the risks resulting from this.

### **Demands on first aider in the company**

In order to be able to guarantee first aid at every accident in the company, it is the employer's duty to create the personnel and material prerequisites for this.

This includes, in particular, trained or further trained first aider. At least one first aider must be present in every group of insured individuals (from two persons present), i.e. in all operating areas, on all construction and assembly sites and in the case of all external work, so that action can be taken at all times at all work locations. Special conditions apply in the case of over 20 insured individuals present.

First aider must have taken part in a first aid course lasting nine hours and, in addition, complete a further training session in an appropriate period (as a rule every 2 years). This training and further training must be carried out by a body authorised by the German Social Accident Insurance Institution. The costs for this are taken over by the competent German Social Accident Insurance Institution.

### **Technical demands on Heads of Operations**

Only persons, who have sufficient theoretical knowledge and relevant practical experience, may be designated by the employer as Heads of Operations. These can be, for example, selected Marshallers. The Head of Operations must be in a position to plan the helicopter assignments, recognise hazards and initiate the required measures as well as work towards the remedying of safety deficits.

**Helicopter pilots can also act as Heads of Operations on site, if they meet the technical requirements and in particular:**

- only one helicopter is deployed,
- no external loads are transported,
- no hazardous goods are transported and
- no ground organisation is needed.

## **3.6 Personal Protective Equipment (PPE)**

Requirements regarding the nature, scope and suitability of the Personal Protective Equipment result from the respective risk assessment for the individual operational procedures.

Suitable Personal Protective Equipment is to be made available to the insured individuals according to Section 2 of the Ordinance on the use of PPE utilisation, if the hazards cannot be excluded by technical or organisational means.

**Personal Protective Equipment is suitable if, for example:**

- it corresponds to the state of the art
- it sufficiently and reliably reduces the identified hazards
- it takes into account ergonomic aspects, such as fit and weight, manageability and possibility of individual adjustability, depending on the work task

- the acceptance of the insured individuals was achieved in wearing/ utilisation tests
- the interactions or mutual influence of protective effects of several items of personal protection do not cause any loss of protection capacity

Appropriate protective equipment is to be available at the company in sufficient numbers, if necessary, individually, due to hygienic and individually ergonomic aspects. It makes sense, for example, to allocate protective equipment against falling personally, in order to avoid constant adjustment to the respective user and therefore to guarantee the protective effect.

An EC type examination must exist for the Personal Protective Equipment made available (except in the case of simple protective equipment, e.g. simple work gloves) as well as an EC declaration of conformity.

The employer has to ensure that Personal Protective Equipment is used in accordance with existing wear time limits and service life for its intended use.

**The following Personal Protective Equipment can be used according to the identified hazards:**

1. head protection, if injury to the head cannot be safely excluded through bumping, by swinging, falling or flying items or loads; for flying personnel, protective helmets with integrated ear protection or protective helmets and ear protection
2. foot protection for assignments on unpaved ground and if foot injuries are to be expected by knocking and trapping, by items falling over, falling down or unrolling, by stepping on pointed and sharp items
3. eye or face protection for work in the downwash and to protect against the sun
4. particle filter masks in the case of expected intensive dust turbulence
5. protective clothing to protect against mechanical impacts, wet conditions and wind

6. high visible clothes for better visibility of persons due to hazards caused by vehicle and flight operation
7. ear protection for work in noise sectors
8. skin protection according to skin protection plan and against solar radiation
9. protective equipment against falling, if the danger of falling exists for insured individuals on board aircraft, in Load Lifting Devices or raised work places and traffic routes

Mountaineering equipment may only be used to protect people against falling, if this is procured and labelled according to the generally recognised rules of technology in trade and industry.

In justified exceptional circumstances, rope systems with suitable Personal Protective Equipment against falling can be used outboard to receive persons, if other devices to receive persons are not possible and the time spent by persons in these systems without sufficient breaks is not more than 10 minutes. Exceptions are permissible, if an ergonomically formed working seat with foot rests is used.

If Personal Protective Equipment against falling is used inside or outside the helicopter cell within the scope of an external cargo transport of one or several persons (Human External Cargo, HEC) or is required for the transport of persons as external loads, this protective equipment against falling becomes a Personnel Carrying Device System (PCDS).

Approval of the Personnel Carrying Device System (PCDS) is required according to aviation certification regulations in the case of a transport of persons as external load on the cargo hook or hoist of a helicopter.



### 3.7 Occupational medical prophylaxis

Occupational medical prophylaxis serve the early detection or prevention of occupational diseases or work-related illnesses. Every employer is obliged to provide health care to his employees. This includes the organisation of the occupational medical prophylaxis. The basis for this is the risk assessment.

The Occupational or Company Physician is to be contacted for the operational selection of occupational medical prophylaxis. He can advise, assess and examine the employees if necessary, regarding occupational medicine.

**In the case of prophylaxis for insured individuals in helicopter companies, the following effects should be taken into account, for example:**

- “Noise”
- “Working abroad under special climatic and health burdens”
- “Spreading of health-threatening plant protection products”.

Occupational medical prophylaxis and aptitude examinations should not be carried out together.

### 3.8 Inspection of work equipment and Personal Protective Equipment

To ensure safety and health protection during the provision and use of working materials the employer has to identify and arrange the necessary inspections for all working materials that are subject to influences causing damage. The nature and use of the working materials, as well as the associated potential hazard are to be taken into account when specifying the inspection periods. The basis here is the risk assessment.

Personal Protective Equipment is also to be checked before starting the assignment, at regular intervals and after exceptional occurrences by a person qualified to inspect.

Exceptional occurrences can be, for example, damage or strain due to a fall or capture.

Protective equipment thus used must be removed from further use until an expert has agreed to further usage.

The results of the inspections are to be recorded in special documents (inspection books). The records are to be kept over an appropriate period, however, until the next inspection at least. If working materials that are subject to inspection are used outside the company, proof of the execution of the last inspection is to be made available.

The insured individuals have to check by a visual inspection working materials and Personal Protective Equipment against falling for proper condition and perfect function before each use.

### **3.9 Communication**

In the case of helicopter assignments communication is necessary between the flying personnel, the assignment personnel on the ground (Marshalls) and possibly additional persons involved. Insufficient or unclear communication can lead to hazards to persons and property.

Wrongly interpreted words or hand signs can immediately trigger an accident or cause damage to property. Clear communication is often impeded by external or personal influences. These can be noise, disorganised work procedures or poor lighting conditions. But inappropriate or uncoordinated choice of words also contributes to problems in communication.

**The following rules are to be observed:**

- Instructions are given by radio, marshalling signals or over the intercom.
- Commands for marshalling count as instructions.
- Hand signs may only be given by instructed and clearly identifiable persons (high visible clothes, coloured protective helmets), whereby the Marshaller must have constant eye contact with the controlling pilot.
- All flight manoeuvres of the immediate operation are carried out on the basis of instructions from the ground or on board.
- The commands are to be referred to the longitudinal axis of the helicopter.
- If there is no perfect communication, the flight manoeuvre must be interrupted.
- A clear stipulation and standardisation of signs, words and terms must be made.
- Radio discipline must be strictly enforced.

# 4 Provision and procurement of working materials for use with helicopters

## 4.1 General requirements

The employer may only provide the insured individuals with working materials that are suitable for the conditions prevailing on the work place and where its intended use guarantees safety and health protection. If this cannot be fully implemented, the employer must take suitable measures to keep a hazard to the insured individuals as low as possible.

Working materials provided must comply with the provisions of the Product Safety Act (ProdSG). If the ProdSG does not apply, it must comply with the other legal regulations, at least however with the requirements of the Ordinance on industrial safety and health (BetrSichV).

All the necessary measures that have to be taken and enforced by the employer for the safe use of working materials are to be identified in a risk assessment according to Section 3.1. In particular, the ergonomic interrelationships between work place, working materials, work organisation, working procedure and work task are to be taken into account in the process.

Essential principle for the choice and priority of the measures is the danger minimisation at the potential hazard. The state of the art, of occupation medicine and hygiene as well as other substantiated findings of occupational research are to be observed in the process.

## 4.2 Demands on helicopters and their equipment

The helicopters to be deployed must be considered to be airworthy according to current aviation law in the case of operation according to the provisions and relevant operating limitations and maintenance. Proof of this is carried out in the airworthiness certificate, issued by the German Federal Office of Civil Aviation (LBA).

This includes the actual helicopter and all attachments (e.g. primary cargo hooks or rescue hoists), which are certified for aviation purposes by corresponding entries in the airworthiness certificate in connection with the helicopter. At the same time, the interface to other legal areas is also here. Facilities and working materials that are attached e.g. to primary cargo hooks or rescue hoists are, as a rule, subject to other regulations. In this way, it is possible that, as a rule, the configuration “helicopter with additional equipment for the area of operation of external cargo flight” in the construction and equipment sector is subject to two different fields of law.

#### Interface primary cargo hook

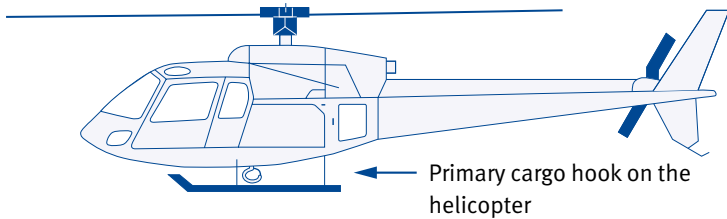

#### Interface hoist

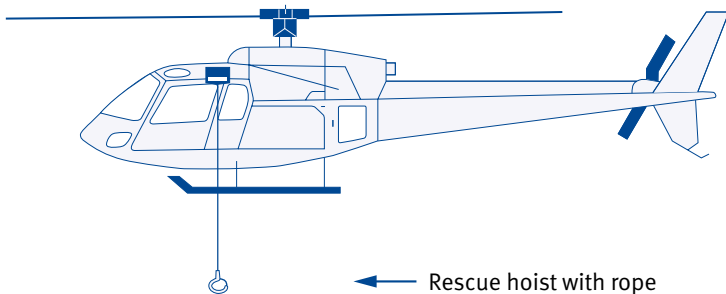

Helicopters are to be equipped with attachments and/or additional equipment by the employer to carry out aerial work according to the assignment requirements.

Helicopters for external load flights must be equipped with suitable attachments to observe the external load, if a second person does not take over the observation on board. Suitable attachments for observation can be:

- mirrors
- camera
- special inspection windows in the cabin wall, door and/or fuselage

Attachments have to be approved according to aviation law (Supplementary Type Certificate – STC).

For persons, who are transported in the helicopter within the scope of assignments or who carry out work on board the helicopter, seats with suitable safety belts must be available.

Helicopters for transporting internal loads must be equipped with suitable facilities for effective load securing. These must be able to be reached and activated without any danger.

Suitable facilities can be, for example, fixed lashing points or variable lashing rail systems.

If the circumstances of the work task do not make it possible to observe the engine monitoring devices to the necessary extent, it may be necessary to install additional display devices in the pilot's field of vision.

## 4.3 Requirements for Load Lifting Devices (LLD)

### 4.3.1 General information

The regulation area “Construction and Equipment” under the helicopter’s primary cargo hook or, for example, from the cargo hook of the hoist fastened to the helicopter, certified for aviation purposes, is allocated to machinery and occupational safety and health law. This field also includes the Load Lifting Devices (LLD include slinging equipments and their components).

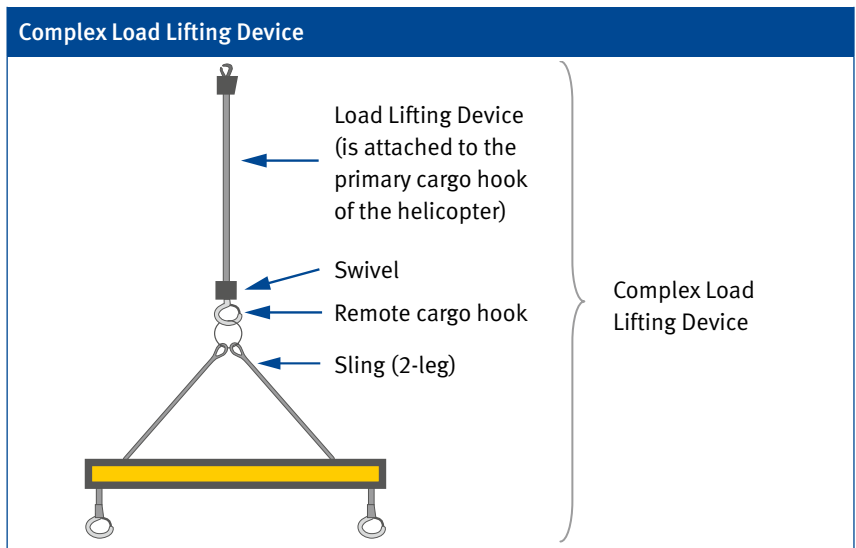

Load Lifting Devices that were placed on the market and put into service for the first time after 1<sup>st</sup> January 1997 are under the scope of the 9<sup>th</sup> Ordinance on the Product Safety Act (9<sup>th</sup> ProdSV). In this ordinance, the machinery ordinance, it is stipulated that machines and safety components must comply with the fundamental safety and health protection requirements of Annex I of the EC Machinery Directive (2006/42/EC), if they are to be placed on the market within the European Union. Slinging equipments and their

components also count as Load Lifting Devices. In this way, the requirements of Annex I of the EC Machinery Directive are also binding for the manufacturer or his authorised representatives of Load Lifting Devices.

A manufacturer's declaration of conformity and an operating manual (instructions) for the use and for the maintenance must be present for Load Lifting Devices (LLD).

The dimensioning of the LLD must be fundamentally selected so that loads can be lifted, transported and deposited safely and failure due to fatigue and wear is excluded.

The LLD must be able to lift the load safely by positive fit and positive connection and equipped with aerodynamic stabilisers, if the rotation of the external load is not prevented in any other way.

The calculation factors for the dimensioning of LLD are to be identified taking the assignment-specific use factors into consideration. Load Lifting Devices for the operation with helicopters must absorb higher levels of force and stress compared to LLD for general hoisting operations due to dynamics, aerodynamics, number of cycles etc. Load Lifting Devices for hoisting operations can be used for the transport of loads with a helicopter, if the specific requirements with regard to dimensioning (e.g. maximum Working Load Limit) are taken into account.

**LLD may only be used if the following markings are present:**

- information on the manufacturer
- construction and material (if this is necessary for safe use)
- CE marking
- maximum Working Load Limit (WLL)

Each part that is not part of an assembly must be marked separately.



Furthermore, an operating manual must be present, **which contains, for example, the following information:**

- intended use
- reasonably foreseeable misuse
- instructions for use, installation and maintenance
- possible limits of use
- load capacity, e.g. in case of containers for bulk goods

Insured individuals must observe the load handling equipment during the usage phase for visible defects (deformations, cracks or wear). The employer has to ensure that load handling equipment with defects that has an impact on safety is removed from further use.

#### **4.3.2 Cargo hooks**

Mechanical cargo hooks should be designed as positive-locking, self-closing and self-locking safety hooks when force is applied. They must be dimensioned and designed in such a way that:

- safe lifting of the slinging equipments to be attached or the load is possible taking into account all expected load forces (load collectives),
- the cargo hook is only directly loaded at the bottom of the hook,
- an overlapping of, for example, lifting belts due to the hook size is avoided,
- a spring-loaded safety catch using a protruding beak form fitted at the tip of the hook prevents unintentional unhooking,
- a cargo hook beak should not or only slightly protrude from the hook's geometry.

In the case of cargo hooks with spring-loaded safety catches (safety traps) the possibility of the sling overturning exists in the event of unfavourable load situations. Self-locking hooks cannot be opened under load.

Basically, no cargo hooks should be used that are only locked by gravity.

Three types of cargo hooks can be differentiated:

- **Cargo hooks for attenuators, for load ropes and multiple leg suspension gear:**

These cargo hooks are generally used for several rotations after each other (e.g. attenuators with load rope). They should be designed as self-closing and self-locking safety hooks. The force transmission of the rope line to the hook is carried out with a connection link.



- **Secondary cargo hooks with swivel at the load cable:**

Secondary cargo hooks can have a cargo hook beak with spring-loaded safety catch. Unlike the safety hook, the secondary cargo hook is used during each rotation. In order to enable the lifting of several round slinging equipments and to be sufficient as ballast at the lower end of the load rope, it should be in an oversized design.

- **Electrical secondary cargo hooks with swivel:**

Secondary cargo hooks with swivel and electric activation fulfil the same function as secondary cargo hooks with swivel. Electric secondary cargo hooks that comply with the state of the art lock the safety trap and can release the load (up to max. permitted WLL) electrically, if necessary.

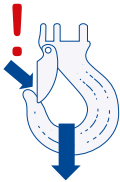
### 4.3.3 Load ropes and ropes of slinging equipments

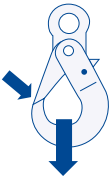
Rule of technology by helicopter transport		
		
Protruding beak only for suspension gear (e.g. concrete buckets)	No beak: better	safety hook: more safe

Ropes to manufacture Load Lifting Devices should be produced by manufacturers, who work according to a certified quality management system.

Load Lifting Devices and slings must be calculated and dimensioned so that they safely carry the load at maximum stress (maximum possible Working Load Limit), taking into account all expected load forces (load collectives), advancing age, mechanical wear and sling technology.

### Ropes made of textiles

Material	High modulus polyethylene	Polyester	Polyamide
Abbreviation	HMPE	PES	PA
Strength in N/mm <sup>2</sup>	360	110	90–95
Ageing pa in %	3%	>3%	8–10%

#### Examples of use

Sling		X	
Connecting element	X	X	
Load Lifting Device	X	X	
Damping element			X

Possible applications for textile ropes/materials (selection)

Fibre ropes (plastic ropes) must consist of synthetic fibres.

**Cables/chains made of steel**

Material	Chain grade 8	Chain grade 10	Steel wire rope
Abbreviation	G8	G10	rope galvanised
Strength in N/mm <sup>2</sup>	1100–1200	1200–1350	1770
Ageing pa in %	no information	no information	no information

Examples of use

Sling	X	X	X
Connecting element	X	X	X
Load Lifting Device	X	X	X
Damping element			

Possible applications for cables/chains made of steel (selection)



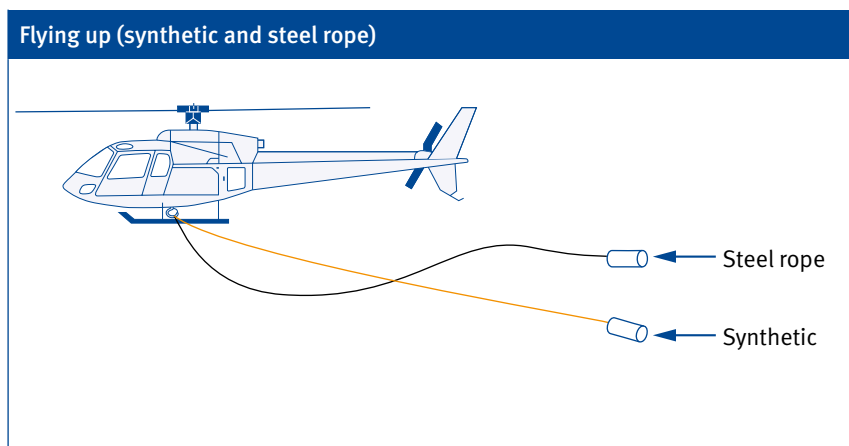

Only low-torque rope constructions made of steel or textile materials may be used to manufacture Load Lifting Devices. Low-torque construction prevents a rope from being able to rotate on its own due to the load on the secondary cargo hook.

If no low-torque constructions are used as slings, these may only be very short slings.

The reaction (flight behaviour) of a lifting or slinging device to a helicopter's forward movement is essentially determined by the material of the rope, the rope's cross section and the distribution of mass between rope and secondary cargo hook.

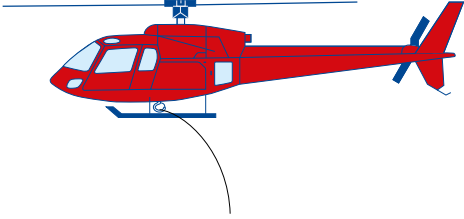

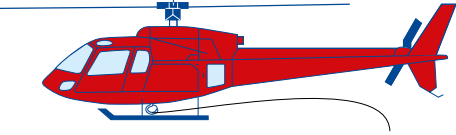
Load ropes made of textile materials (synthetic fibres) with a circular cross section offer much better controlled and less aggressive flight behaviour due to the material characteristics compared with steel ropes. They are characterised by slower movements and an extremely low oscillation behaviour (upward swinging of narrow objects in the air stream). Cross sections that are not circular, e.g. rectangular cross section (lifting belts) are not to be recommended, as they swing up or fly up aggressively, especially in the case of descent flight.

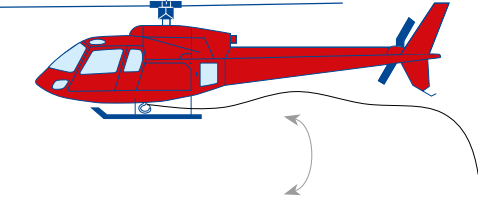
Description	Principle
<p><b>Circular cross section</b> Best aerodynamic behaviour.</p> 	
<p><b>Oval cross section</b> Problematic. “Wobbles” during flight and produces relatively strong lift.</p> 	
<p><b>Rectangular cross section</b> Extremely problematic during use as load rope. Strong vacillations (vibrations perceivable on pitch or stick), accessories and nooses can be damaged. Strong lift and strong whipping.</p> 	
<p><b>Cross sections of multiple legs (round, oval or rectangular)</b> Multiple leg load rope, extensions or long-legged slinging equipments vibrate strongly and produce very high resistance = lift.</p>	

**In order to minimise the uncontrolled upsurge of load ropes in case of sudden relief (e.g. loss of load) and risk of damage to the helicopter or load rope associated with this, the following possibilities exist:**

- use of low-torque load ropes or rope constructions with low elongation (< 2 %) (use of e.g. polyamide lifting belts or polypropylene braided sheathing as Load Lifting Devices or slinging equipments is questionable and not to be recommended)
- use of long load ropes (Long Line load ropes)
- positioning of damping elements between helicopter and Load Lifting Devices
- in case of rope combinations the load rope with the lowest mass on top and the greater mass fly at the bottom
- positively influence upsurge behaviour by attaching a specific mass (additional mass) to the secondary cargo hook
- selection of load ropes with increased carrying capacity (WLL)
- stiffening of the rope

Electric cables should be placed within the rope geometry for electromechanical functions.

To minimise the impact of hard blows to the load rope, attenuators (shock absorbers) are used. This can however favour the effect of sudden upward movement, which is especially undesirable in the case of short ropes.

#### **4.3.4 Rope end connections**

Rope end connections should be produced by manufacturers, who work in accordance with a certified quality management system.

Rope end connections must be suitable for the respective intended purpose and comply with the rules of technology.

**The following items are used:**

- The **spliced end rope** – it is a break-proof, permanent, non-detachable connection of the rope end with the rope by braiding the individual strands (rope parts). It transfers 85 % of the minimum breaking force of the rope in the case of standard-compliant versions. Splicing work may only be carried out by trained personnel.
- The **aluminium ferrule** – it is one of the most common rope end connections and transfers 90 % of the minimum breaking force of the rope in the case of standard-compliant versions. The pressed sleeve should end cylindrically tapered on the open rope.

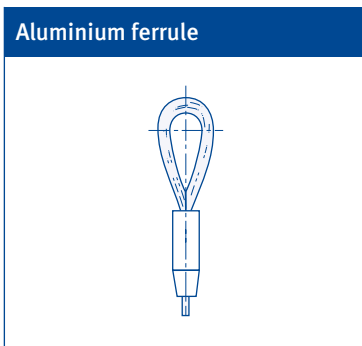

- The **spliced core-cover** in textile bound ropes – it is a break-proof, permanent, non-detachable connection of the rope end with the rope by introducing the tapered rope end into the core of the same rope. It transfers 85% of the minimum breaking force of the rope in the case of standard-compliant versions. Splicing work may only be carried out by trained personnel.
- The **flemish eye** (in German “Flämisches Auge”) – it is a special form of rope end connection. Strands are placed here in the opposite direction to a rope eye and fixed with a pressed sleeve made of steel. The advantage of the flemish eye is the considerably higher carrying capacity due to the symmetrical force distribution. In the case of standard-compliant manufacture, up to 100 % of the minimum breaking force of the rope can be transferred.



Rope loops are fundamentally to be executed with a suitable thimble. This must have an adequate width and match the respective fitting. As textile ropes in particular do not have any dimensional stability, thimbles must be executed here in a very dimensionally stable manner or with a welded-in wedge.

Pointed thimble of form A with rounded tip for steel ropes

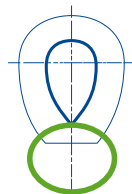

#### 4.3.5 Lifting belts and round slinging equipments

Strap fabric for lifting belts and round slings must be manufactured from synthetic fibres only. They are mainly made of polyester (PES) for use with helicopters. Materials such as polyamide (PA) or polypropylene (PP) are not suitable because of too much stretch and too high moisture absorption.

Lifting belts tend to oscillate during inflow due to their rectangular cross section and are sensitive to flattened or twisted fastening.

Round slings are applicable in a versatile way and can therefore be attached even if somewhat twisted, stacked or bundled.

The carrying capacity of a lifting belt or a round sling in the type of slinging “Direct” is indicated by the colour of the round sling’s cover or an individual part of the sewn strap.

The maximum Working Load Limit (WLL) of a flat woven lifting belt, a lifting belt unit or a round sling for assignments with helicopters must be determined by the user from the WLL of the lifting belt or the round sling by multiplication with the assignment-specific use and sling factors before the respective assignment.

Loops on the ends of the lifting belts can be reinforced in order to protect the loop's inner surface against damage during lifting and the tying point in the noose.

Suitable reinforcing materials are, for example, loop or strap fabric, leather or other resistant material.

The synthetic fibres the lifting belt was manufactured from are prone to a deterioration of their properties, if they are exposed to radiation with ultra-violet light (e.g. sunlight). Flat woven lifting belts or round slings should not be exposed to direct sunlight or sources of ultra-violet radiation for longer than necessary or stored under their influence.

Storage should be on a shelf in clean, dry and well-ventilated surroundings, away from heat sources, without contact with chemicals, fumes or corroded surfaces (e.g. rust deposits).

The marking of a lifting belt or a round sling must be legible and indelible on a label that is fastened directly to the lifting belt or the round sling. For reference purposes, there is a further label underneath a seam.

**The following minimum details are needed for the user:**

- carrying capacity of the lifting belt or the round sling in case of direct attachment
- material (polyester, polyamide, polypropylene)
- grade of fittings
- nominal length in metres (m)
- name of manufacturer, symbol, brand name or other unambiguous identification
- traceability code (for the individual basic elements)
- number of the European standard
- maximum angle of inclination of a leg to vertical in the event of multiple leg round sling suspension gear

#### **4.3.6 Round steel chains**

Round steel chains should be produced according to the relevant standard, be made of high-strength steel and short-linked.

The maximum Working Load Limit (WLL) of a sling or Load Lifting Devices made of round steel chains for assignments with helicopters must be determined by the user from the WLL of the sling or Load Lifting Devices by multiplication with the assignment-specific use and sling factors before the respective assignment.

If used as a sling with cording, the maximum Working Load Limit (WLL) is limited to 80% of the marked Working Load Limit.

Round steel chains are particularly suitable for fastening loads with sharp edges or rough surfaces (e.g. iron bars). If necessary, they must be secured against slipping due to low friction between sling chain and e.g. a load of metal.

Multiple-leg sling chains must always be stably attached to the load with all individual legs.

Sling chains that are not in use should be stored hanging in a specific rack.

As well as the regular inspection of the round steel chains by an expert/an authorised inspector according to the Ordinance on industrial safety and health, round steel chains that are used as slinging equipments must undergo a special inspection (e.g. non-destructive testing procedure) for absence of cracks. This is to be carried out at intervals of max. three years, taking the manufacturer's instructions into account.

#### 4.3.7 Personnel Carrying Device System

Personnel Carrying Device Systems (PCDS), which are used to transport persons as external load on the helicopter, are to be hooked into the cargo hook or the rope hoist.

Personnel Carrying Device Systems must have an airworthiness permit.

The airworthiness permit for PCDS of complex design – for example, cages for personnel transport, nets, Personnel Carrying Devices for double cargo hooks (quick release systems) or other mountain rope systems without a standard conformity (EN conformity) – has to be carried out in accordance with the criteria of a significant constructional modification and is to be certified according to CS 27/29.865 and the corresponding guidelines.

The airworthiness permit for PCDS of simple design – for example, Personal Protective Equipment against falling in the sense of the EC Directive 89/686/EEC, to be used for max. two persons and manufactured in compliance with a harmonised EN standard or means to secure a person operating the hoist or the cargo hook in the cabin, provided that the Personal Protective Equipment against falling used has an EN-compliant permit – can be carried out in accordance with a simplified permit procedure.

**The unrestricted compatibility between the helicopter and the PCDS is to be determined by the employer. This includes, in particular:**

- the unimpeded mounting and demounting of the PCDS in the helicopter cabin,
  - the inclusion of the PCDS in the hoist hook,
  - the inclusion of the PCDS in the primary cargo hook,
- so that an unscrewing or tilting in the cargo hook is excluded.**

#### **4.3.8 Other Load Lifting Devices**

Adjustable traverses must be equipped with form-fit and force-fit safeguards of the moveable parts. Where necessary, they are to be fitted with aerodynamic stabilisers.

**If reusable Big Bags (FIBC) are used, these must comply with DIN EN ISO 21898 (safety factor of at least 6). In addition, for the helicopter transport:**

- the lifting belts are to be adequately dimensioned (four-leg suspension gear)
- the lifting belts are to be at least 1 m long and sufficiently sewn at the ends
- the lifting belts are continuously sewn all round, crosswise on the bottom and up to the beginning of the loops
- the lifting belts are to be sewn between a double bottom
- the necessary manufacturer's details (e.g. maximum Working Load Limit, pictograms for lifting) are to be mounted or printed on a large scale and permanently on the sides
- no openings are to be planned on the bottom

#### **4.3.9 Individual parts for complex Load Lifting Devices (connectors)**

The connection means (shackles, connex or connection links) must be suitable for the planned assignment and calculated and dimensioned in such a way that they safely carry the maximum load taking into account all expected load forces (load collectives), advancing ageing and mechanical wear.

Shackles have not proved their worth for the permanent connection of e.g. Long Lines. It is possible that they can be opened by blows or other external impacts.

Shackles must be secured with additional devices for force-fit security.

These can be, for example, cable ties, safety splints or safety wires.

Short-term connection with shackles must be checked for proper condition before each assignment.

Swivels or rotating swivel hooks can also be used as connecting links. These are to be checked for their ease of operation of the rotating insert before the assignment.

Rotating swivel hooks with ball bearing are designed exclusively for slinging equipments. They are only used to offset torsion in multiple-leg suspension gear.

Every connector must – without negatively influencing the properties of the individual part – be marked legibly and permanently at a place, which is not impeded by use.

**This marking must contain at least the following information:**

- nominal size
- the grade code number
- name, sign or brand of the manufacturer
- traceability code
- CE marking

## 4.4 Other working materials

Working materials provided must correspond with the respective conditions of the assignment.

Lashing materials to secure the load in the helicopter must be adequately dimensioned and designed so that they can be safely connected to the lashing points in the helicopter.

### **Lashing materials are for example:**

- lashing belts made of synthetic fibres
- steel wire ropes
- lashing chains
- load securing nets (lashing nets)

The dimensioning of the lashing materials has to be carried out on the basis of the calculation specifications of VDI 2700 sheet 2. The acceleration values to be assumed in the case of helicopter flights, the load distribution and the possible stresses of the lashing points of the helicopter can be found in the respective “Aircraft Flight Manual” (AFM).

# 5 Setting up outside working stations and flight routes

## 5.1 General requirements

**Outside working stations must correspond to the permit requirements. In particular, the following conditions are to be taken into account:**

- They are to be created at the greatest possible distance from urban or used areas.
- Residential areas, crowds of people, busy roads and bridges may only be flown over in exceptional cases and for short periods.
- They must be free of loose objects or obstacles. Excessive dust development is to be avoided during flight operation.
- The touchdown area must be firm and level.

**Remark:** Requirements on the exterior landing place are stipulated by the competent regional authorities. See also “Guidelines for granting general permits for the assignment of helicopters – new edition of 2010“.

**Furthermore, the following measures are to be carried out before starting flight operations:**

- fencing off against unlawful entry of third parties (e.g. fences, chain barriers)
- equipping with fire extinguishing appliances and sufficient first aid material
- mount equipment to recognise the wind direction
- select parking areas for vehicles with safest possible approach and mark entrance and roads if necessary
- if necessary consolidate the parking areas for helicopters and vehicles as well as runways and roads taking the weather situation into account
- mount no-smoking signs



## 5.2 Load pick-up and load drop-off places

**Load pick-up and load drop-off places on outside working stations must be suitable for the planned work assignment. The following requirements are therefore to be taken into account, among others:**

- sufficiently large and suitable spots
- clear division in exterior landing place and load pick-up and drop-off place
- creation of options to use Personal Protective Equipment at work places at heights by the employer, allocation of suitable fastening points for the PPE of the insured individuals against falling

## 5.3 Jettisoning and emergency landing places

Suitable areas are to be designated and prepared before starting work in order to be able to drop off an external load without additional hazards for persons and property or to possibly land the helicopter, if necessary. The scheduled flight routes must be coordinated in relation to the emergency drop-off and emergency landing places.

## 5.4 Refueling places

Refueling places must be designed and organised in such a way that aircraft fuel is stored safely and helicopters can be safely refueled.

**The dimensions must guarantee the following protective distances:**

- 10 m between buildings and refueling equipment
- safety distance of 5 m between the main rotor circle or the tail of the helicopter and the refueling equipment

They must be equipped with fire extinguishers in a quantity that corresponds to at least 18 extinguishing agent units (EAU).

# 6 Assignment-specific measures

## 6.1 Refueling helicopters

This is a summary of the most important safety requirements for the refueling of helicopters from non-stationary refueling systems.

### 6.1.1 Aircraft fuel

Common types of aircraft fuel are JET A-1 (kerosene) for turbine engines and AVGAS 100 LL (aviation petrol) for piston engines. Both varieties are detrimental to health in case of inhaling concentrated vapour-air-mixtures and flammable or explosive under certain temperature and air circulation conditions. The specification LL (low-leaded) or UL (unleaded), for example, is used for the precise designation of the fuels in the case of AVGAS and the specification JET A-1 or JET-B, for example, in the case of kerosene. In order to be able to judge the fire or explosion hazard quantitatively, key indicators, e.g. the flashpoint, the ignition temperature or the lower and upper explosion limit are determined.

Types of aircraft fuel	JET A-1	AVGAS 100 LL
Flashpoint	above +38°C	below -18°C
Hazard class	flammable	extremely flammable
UN number	UN 1863	UN 1203
Class	3	3
Classification code	F1	F1
Packaging group	III	II
Ignition temperature	approx. +220 °C	approx. +220 °C
Explosion limits in air	approx. 0.6 to 6.5 Vol.-%	approx. 0.7 to 8.0 Vol.-%

The safety data sheets of fuels contain further information.

Whether normal commercial vehicle fuel (MOGAS – e.g. “Super Plus 98”) may also be used, is stipulated in the flight manual. If no stipulation was made here, the manufacturer of the helicopter must grant an approval.

### 6.1.2 Mobile refueling stations

#### *General requirements*

Different types of refueling can be considered depending on the type of assignment and helicopter class, e.g. refueling from airfield fuel trucks, tankers, demountable tanks, fuel containers or canisters. According to hazardous goods law approved Intermediate Bulk Containers (IBC) are packages for transport and therefore not “mobile filling stations”.

The relevant legal regulations for storage apply in the event of an interruption of transport of aircraft fuel of more than 24 hours. In particular, the aircraft fuel must be stored in such a way that leaking fuel can be detected, collected and eliminated.

The length of the refueling hoses is to be selected so that a minimum distance between feed pump and helicopter can be guaranteed according to the table “potentially explosive area during refueling of helicopters”. Coupled hoses are to be avoided.

Refueling with the engine running (hot refueling) is possible with JET A-1 (turbine helicopter), if there are special technical or safety reasons for this and appropriate safety measures to protect the insured individuals are taken.

**Technical or safety reasons that permit refueling with the engine running exist among others, if:**

- the wind conditions do not permit restarting the engine or rotor or
- several short flight intervals (rotations), during which continuous refueling procedures are necessary due to the operation, would thermally overload the engine by repeated restarting.

**Suitable safety measures are, for example:**

- The refueling personnel is given special instructions.
- Reliable communication helicopter pilot/refueling personnel is ensured.
- A third person is deployed for cordoning off the danger zone.
- The delivery valve is secured against slipping out of the filling neck on the helicopter side.
- The delivery valve is not directed against the engine intake duct.
- The distance of the rotor area level to the refueling station and to trees or objects of at least 5 m is maintained. The distance to buildings and facilities must be at least 10 m.
- The helicopter pilot remains seated during refueling with his/her seatbelt fastened.
- Approaching the helicopter is only carried out at the request of the helicopter pilot.
- Special attention is to be paid to the rotor disk area and its distance to the ground when approaching the helicopter.

Due to the high explosion hazard, hot refueling is forbidden under all circumstances in the case of engines that are operated with AVGAS.

**Danger zones**

A safety distance of at least 10 m is to be maintained at all times to protect buildings, facilities or the helicopter from possible fire hazards.

If the formation of an explosive atmosphere cannot be safely excluded during the refueling process, protective measures are to be taken depending on the classification of the potentially explosive areas.

The appearance of explosive atmosphere can be expected especially in the area of openings, from which gas mixtures can escape. As a result of this fact, it is necessary to prepare an explosion protection document according to the Ordinance on industrial safety and health (BetrSichV).

**The explosion protection document must mention, in particular,**

- that the explosion hazards on the refueling place have been identified and subjected to an evaluation,
- that appropriate precautions and measures are taken to combat the hazards and achieve the goals of explosion protection,
- which areas were divided into zones,
- for which areas which minimum regulations apply and according to which criteria working materials are to be selected and
- which organisational measures are required.

The expansion of the explosive atmosphere depends on the volume flow and the type of fuel (flashpoint) and has the shape of a truncated cone over the discharge opening.

Furthermore, an area (full circle) with a radius of 5 m and a height of 0.8 m is to be adopted as Zone 2.

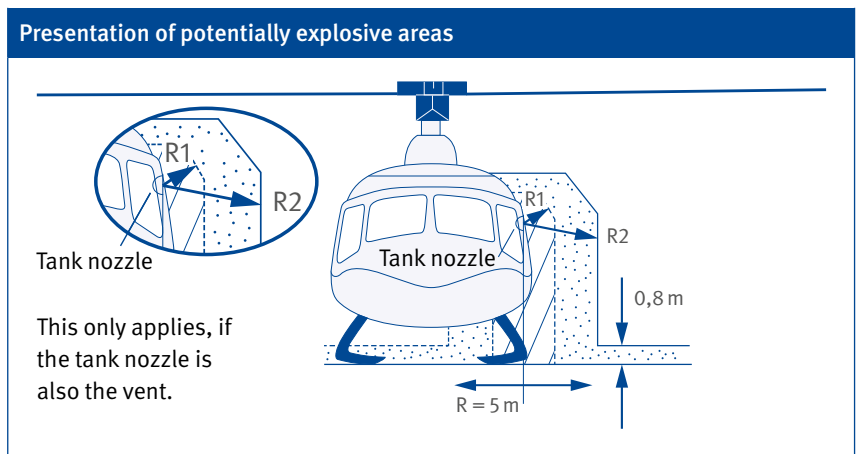

The appearance of an explosive atmosphere is occasionally to be expected in the area of Zone 1 during normal operation and in Zone 2 only briefly or not to be expected.

**Areas with explosive atmosphere during refueling of helicopters**

Volume flow of the refueling pump [l/minute]	Type of fuel	Danger zone Zone 1 radius R1 [m]	Danger zone Zone 2 radius R2 [m]
<100	AVGAS 100 LL	1	3
	JET A-1	0	1
<600	AVGAS 100 LL	5	8
	JET A-1	0	1

Protective measures are to be taken in potentially explosive areas that prevent or restrict the danger of the ignition of dangerous explosive atmosphere or limit the impact of an explosion to an extent that they can be considered harmless. These include, for example:

**Zone 2:** Ignition sources to be expected during operation (ignition sources that can arise during normal, smooth operation, such as during switching operations on the wiring system or radio devices) are to be avoided.

**Zone 1:** In addition to the ignition sources stated for Zone 2, ignition sources caused by operational disruptions, which must be expected from experience (malfunctions that are realistically to be expected) are also to be avoided. Operating materials, installations and plant parts, where the appearance of ignition sources can be expected, must have an explosion-proof design and, if necessary, be spark-proof.

Furthermore, a danger zone with a radius of 5 m around the mobile refueling station and the feed pump with the hazard level corresponding to Zone 2 is to be adopted. These danger zones are to be marked with

prohibition signs “No open flame; fire, open ignition source and smoking forbidden” and “Access by unauthorised persons forbidden”.

Signs that comply with the Technical Rules for work places “Safety and Health Protection Signs” (ASR A1.3) are suitable.

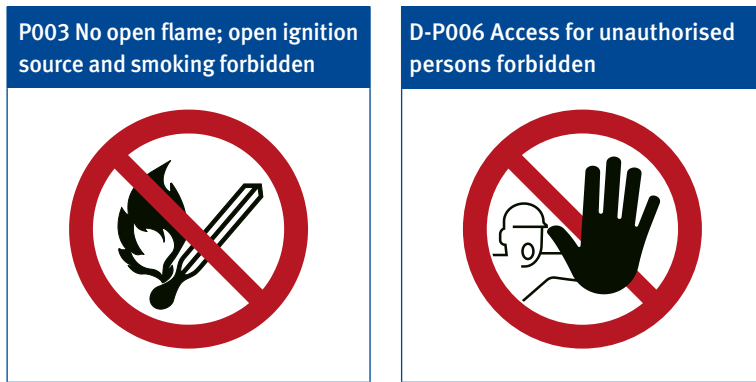

### **Fire protection equipment**

Suitable fire extinguishers to fight an incipient fire are to be provided in sufficient number corresponding to at least 18 Extinguishing Agent Units (EAU).

Suitable fire extinguishers are, for example, powder extinguishers with ABC dry powder of type PG 6 (6 EAU) and PG 12 (12 EAU).

### **Environmental protection equipment**

If any mobile tanks used are not double-walled, these are to be placed in adequately dimensioned vats that are made of conductive and non-flammable material. This also applies for barrels and canisters. The entry of rainwater must be prevented, as this reduces the possible collection volume.

In order to avoid soil contamination when decanting and refueling, suitable collecting vessels are to be provided.

If spills, dripping or leakages have occurred, leaked fuel must be absorbed immediately with suitable binding agents and disposed of correctly.

Mobile refueling is to be avoided in water protection areas. Where it is unavoidable, coordination with the regionally competent authority for water protection is urgently recommended.

### **Refueling process**

To guarantee safe fuel applications, a type-compatible, clean fuel that is free of impurities is important. In particular, it must be ensured that no water constituents are contained in the fuel, as fuel is in a position, depending on its temperature, to store water invisibly.

In order to ensure a reliable supply of aviation fuel, a needs-based and punctual delivery is required. It is to be taken into account that a sufficient settling time of the delivered aviation fuel in the storage tank is complied with before the first refueling. In this way, possibly existing condensation and other impurities can settle at the bottom of the container. Samples are to be taken at the tank's low point before first refueling, in order to check whether the fuel is flawless.

Refueling may not be carried out within the sphere of influence of a thunderstorm. Thunderstorm situations, from which risks can arise, are not clearly defined. It is to be assumed that discharges capable of igniting are possible in the case of storm fronts that are at a distance of 5 to 6 km. The thunder is already easily audible at this distance.

The helicopter is to be parked ideally on firm and level ground and secured against rolling away, if necessary. The refueling Marshaller must coordinate with the pilot before starting the refueling process. In particular, all the necessary work steps for refueling are to be coordinated, in order to minimise a reciprocal hazard especially during refueling with the engine running.



Risks due to electrostatic charges exist during every refueling process. In order to reduce these to a minimum, conductive connections (equipotential bonding) between the helicopter and the refueling system or the refueling device must be secured.

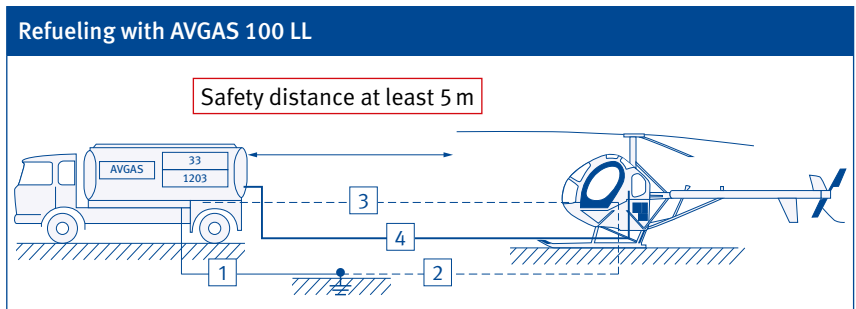

**When refueling with AVGAS 100 LL from permanent or mobile stations, the following technical or organisational measures are necessary:**

1. connect tank container or vehicle with an earthing point (earth pin)
2. connect helicopter with the earthing point
3. connect the earthing cable of the tank container or vehicle with the helicopter
4. roll out the hose, open the tank, introduce the delivery valve into the tank and refuel

Dismantling at the end of the refueling process is carried out in reverse order.

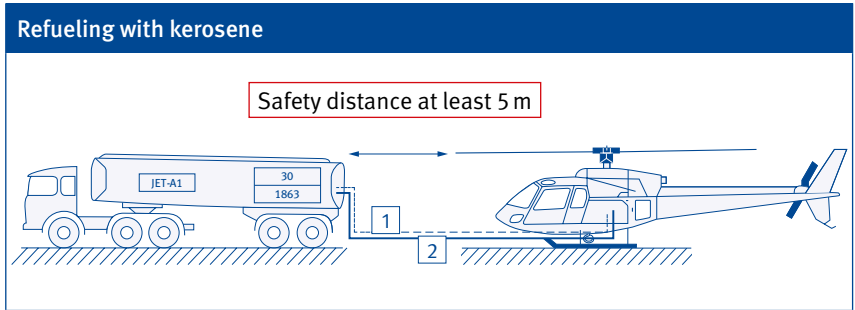

**When refueling with kerosene from permanent or mobile stations, the following technical or organisational measures are necessary:**

1. produce electrical connection to the equipotential bonding between tank container or vehicle and the helicopter
2. roll out the hose, open the tank, introduce the delivery valve into the tank and refuel.

Dismantling at the end of the refueling process is carried out in reverse order.

The prescribed and marked connection points (bonding points) are to be used to produce a sufficiently conductive connection.

### **Health protection**

The inhaling of vapours is to be avoided. Clothing that has been in contact with fuel is to be changed immediately due to fire hazards and irritations of the skin.

### **Overfills and spills**

**In the event of overfills and spills, due to the existing fire and explosion hazard, immediately after the interruption of refueling and the closing of the valves:**

- the motors, engines and electrical installations are to be switched off
- the hazard area is to be secured or cordoned off

The amount of liquid is to be curbed as far as possible and absorbed with oil binding agents.

## 6.2 Luggage and internal cargo

Luggage and other internal cargo must be secured in the cabin in such a way that the crew members and other passengers cannot be endangered or injured during normal flight operation or an emergency landing.

**For this the following measures or prerequisites are necessary, for example:**



- Cargo or luggage is only to be transported with a helicopter, if it is really necessary.
- Every object that is taken or transported in the cabin of a helicopter must be sufficiently secured against slipping or unintentional movements.
- The permissible load capacity (surface pressure) of the load compartment floor may not be exceeded.
- When stowing luggage under the seats, this must be fastened with appropriate equipment.
- The function of seats may not be influenced by the stowing of luggage under the seats.
- Flaps of luggage compartments must be able to close properly.
- The access to emergency exits or emergency equipment may not be impeded by luggage or internal cargo at any time.
- A renewed check of the safety of the cargo may be necessary during the flight.
- Necessary cargo-specific fixation points in the helicopter and appropriate lashing materials are available.
- The location of the cargo's centre of gravity permits a transport with the helicopter.



The calculation of the lashing forces or the necessary lashing materials has to be carried out on the basis of the relevant demands of the "Aircraft Flight Manual" (AFM) in this respect.

If **internal cargo goods** can only be transported with the doors open, the open doors are to be secured or removed. Flying with open doors is only permitted if this is described and approved in the flight manual.

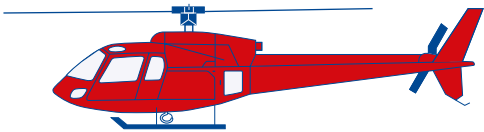
### 6.3 External cargo and installation flights

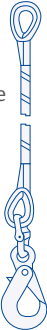
The helicopter must have available a weighing system to determine the load.

Reasonable set-up of complex load bearing equipment for external loads (additional equipment)	
<p><b>Helicopter with primary cargo hook</b></p>	
<p><b>Shock absorber (attenuating element)</b> Polyamide rope, double or 4-fold, loose or jacketed, operating elongation approx. 15% length 1 to 2 m, end fitting for primary cargo hooks according to manufacturers' specifications</p>	
<p><b>Lifting rope systems of sufficient length</b> Low-torque steel rope (e.g. crane lifting rope) or synthetic fibre ropes with low elongation, cross section circular, as small as possible, weight in relation to cargo hook as low as possible, operating elongation as low as possible</p>	<p>Short Line L &lt; 20 m</p> <p>Long Line L &gt; 20 m</p> 

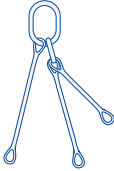
Reasonable set-up of complex load bearing equipment for external loads (additional equipment)	
<p><b>Swivels</b> Torsion tensions cannot be absorbed by cables</p>	
<p><b>Cargo hooks with sufficient dimensions</b> Manual or electrical end fitting for primary cargo hooks according to manufacturer's specifications</p>	
<p><b>Slings</b></p>	

The overall length of the load rope including swivel and cargo hook should be significantly below or above 1.5 times the rotor diameter.

### Flight operation

The **helicopter pilot** must ensure the safe lifting or setting down of the external load under all possible flight conditions.

### Measures for safe load lifting

The helicopter is centred over the centre of gravity of the external load and the Load Lifting Devices tightened by slow vertical ascent. Only then is the load lifted. It is safeguarded by the Marshallers that no further persons are in the hazard area. Foreign bodies, loose parts or covers on or at the load are to be removed beforehand.

### **Measures for safe offloading**

The external load is positioned over the storage or installation area and slowly set down according to the work task. With this guiding lines are to be handled freely. They may not be entangled or tied. Oscillating loads are to be avoided, as manual damping is not possible in most cases.

It is ensured by the Marshallers that only those persons that are necessary to the immediate continuation of work are in the danger zone. The fine positioning, the setting down or a necessary jacking of the external load is directed or monitored by the Marshallers.

### **Measures in the case of assignments using Long Line**

A flight procedure with the necessary approach or departure height is to be selected, if a Long Line is used. In order to prevent a flying up of the complex Load Lifting Devices in the case of transfer flights with a Long Line, negative vertical accelerations or too high forward speeds are to be avoided. If necessary, additional weights or other aerodynamic components are to be mounted on the lower end.

### **The helicopter pilot must inform him/herself or be informed of the position of the external load during the whole flight. This can be carried out by**

- external mirror or bubble on the helicopter,
- a Marshallers on board (external load instructor),
- a Marshallers on the ground, who is in constant audio connection with the pilot.

The whole flight involves load lifting, transport and offloading down. If necessary, different measures must be combined with each other.

**The Marshallers** has to ensure that external loads are safely attached and cannot come loose unintentionally. Before lifting or setting down the load, the electrostatic charge is to be discharged from the helicopter cell, the load or the complex Load Lifting Devices.

**Suitable measures here are, for example:**

- contact of the Load Lifting Devices with the ground before lifting the load
- ground contact of the helicopter before lifting the load
- grabbing hold of the load or the Load Lifting Devices using a sufficiently earthed arrestor hook, in order to discharge electrostatic charges properly

Marshalls on the ground wear high-visibility work clothes, which clearly stand out from the colouring of the other insured individuals, appropriate for seasonal weather and the assignment area, e.g. high visibility clothing according to DIN EN ISO 20471.

The employer must provide a sufficient number of Marshalls to shorten the assembly and dismantling time and therefore the "confined area" situation of the helicopter. This must be oriented on the type and extent of the work task.

The safety distance to live overhead power lines must be at least 5 m.

A suitable emergency landing place for the helicopter and a jettisoning area for the external load must be determined before starting work. This is to be fenced off for the period of work and secured against access by third parties.

Further measures to minimise hazards can result from the risk assessment.

## **6.4 Flights with bulk goods**

Flights with bulk goods are external load flights as a rule, during which solid materials (lime, fertilisers, seeds, granulates, vaccination baits etc.) are spread.

### **Additional equipment**

**For the spreading of solid materials the following can be used, for example:**

- spreading containers for lime, fertilisers, seeds and granulates,
- discharge devices for vaccination baits and
- fixed incorporated spreading devices.

Power-operated spreading devices may be subject to the application area of the Machinery Directive. In these cases a declaration of conformity and a label (CE marking) are necessary.

Fixation on the helicopter should be carried out in such a way that the actual container is not in the area of the maximum downwash (about 1.5 times the rotor diameter).

Additional visual aids (such as mirror or camera systems) enable visual contact and regular observation of the function of the spreading devices.

If the possibility exists that the helicopter's maximum Working Load Limit can be exceeded by the lifting of a spreading device, there must be a system visible to the helicopter pilot to determine the load.

### **Flight operation**

In order to avoid the clumping or blockage of the spreading device, the solid materials must be stored and processed dry according to the manufacturers' instructions. Only the amount that is necessary for the immediate continuation of work is to be kept at the actual loading point of the containers. It must be ensured when loading the container with bagged goods that emptied sacks and other transport media cannot fly around due to the helicopter's downwash and jeopardise the safe flight operation.



Employees, who are designated by the employer to operate earth-moving machinery (e.g. wheel loaders) to load the containers, must be sufficiently qualified to do so.

Nobody may be in the danger zone at the time of setting down the load or picking up the load in the case of the bucket changing procedure using straps and hooks.

Further measures to minimise hazards can result from the risk assessment.

## 6.5 Flights with spray media

Flights with spray media are flights for the spreading of liquid plant treatment agents in agriculture, forestry and wine growing.

### **Additional equipment**

**For the spreading of plant treatment agents for example:**

- baskets
- spraying devices or systems

can be used. The spraying device or system must comply with the requirements of the regulation on plant protection products and plant protection equipment and the directives for spreading plant protection agents using aircraft. This can be carried out, for example, with a sample approval or a complementary approval of the device or system in connection with the helicopter.

All ground working materials for the preparation and pumping of the spraying agent must also comply with this regulation and the directive.

Display equipment is necessary within the visual range of the helicopter

pilot in order to operate a spraying device or system, to make the operating pressure in the system visible, the switching status of the spraying valve and the indication of the remaining amount in the spraying agent container.

### **Flight operation**

The assignment for the spraying of liquid plant treatment agents must be reported to the competent authority according to the directives for spraying plant protection agents using aircraft.

The personnel (also external) deployed by the employer must have specialist knowledge and skills in handling plant treatment agents. The helicopter pilot should have completed training in the field of crop spraying.

The employer has to ensure appropriate occupational medical prophylaxis on the basis of the risk assessment.

If several helicopters are used, the employer has to organise the necessary coordination about safe flight execution.

To ensure a homogeneously high spreading quality wind direction indicators, wind speed, temperature and air humidity measuring devices are useful tools.

Further measures to minimise hazards can result from the risk assessment.

## 6.6 Inspection flights on overhead power lines and pipelines

Inspection flights are flights during which persons in the interior or the helicopter pilot carry out visual checks or observations with or without observation equipment.

### **Additional equipment**

**For the observation the following equipment can be used:**

- infrared cameras
- video cameras
- cameras
- binoculars
- thermal imaging cameras

Observation equipment can be hand-held or fixed to or in the helicopter, whereby only aviation authority approved equipment may be permanently mounted.

### **Flight operation**

Sufficient visibility conditions, e.g. through opened sliding windows, are to be ensured for the helicopter pilot and observers, oriented on the observation task.

Additional persons in the interior (observers) are to be provided with assignment-specific Personal Protective Equipment (e.g. ear protection) and communications equipment.

Further measures to minimise hazards can result from the risk assessment.

## 6.7 Measuring flights

Measuring flights are helicopter assignments, where air or water samples are recorded or measurements, e.g. on transmitting power or seismology, are carried out.

### **Additional equipment**

**For taking samples or carrying out measurements, for example:**

- air sample measuring devices,
- water sample extraction devices,
- transmission and receiving systems and
- measuring probes

can be used.

### **Flight operation**

Before the execution of the assignment, within the framework of a briefing, the employer has to inform the employees about potential hazards in connection with the work task (e.g. the existence of hazardous substances) and is to take suitable assignment-specific measures. Special activities (such as taking samples while using respiratory protection) must be described in written operating instructions.

If taking the sample or the measurement can only be carried out with the door open, the helicopter must be suitable for this (manufacturer's release).

Further measures to minimise hazards can result from the risk assessment.

## 6.8 Fire-fighting/forest fire-fighting flights

Flights to combat forest fires are external load flights, whereby extinguishing agents are jettisoned to combat fires.

### **Additional equipment**

**For the transport and spreading of extinguishing agents, among others:**

- water dropping systems (e.g. Bambi Buckets) and
- extinguishing agent dosage systems

can be used. This additional equipment can be provided with aviation authority approvals.

Power-operated water dropping systems that are operated as external load are to be allocated to the application area of the Machinery Directive. In these cases a declaration of conformity and a label (CE marking) are necessary.

Fixation on the helicopter should be carried out in such a way that the actual container is not in the area of the maximum downwash (about 1.5 times the rotor diameter).

At the same time, it must be prevented that it can reach the tail rotor in the case of strong swinging up of the container.

### **Flight operation**

Special regulations for the execution of flight tasks are issued by the local operations units within the scope of disaster assignments. The employer must coordinate the preparatory and accompanying coordination of the assignment with the disaster operations centre.

Further measures to minimise hazards can result from the risk assessment.

## 6.9 Photo and film flights

Photo and film flights are flights where recordings as images or image sequences are created using image recording equipment.

### **Additional equipment**

Stabilising devices are used to fasten the recording devices on the helicopter. These may require aviation authority approvals.

### **Flight operation**

If the image or image sequence recording can only be made with the door open, the helicopter must be suitable for this (manufacturer's release). Additional persons in the interior are to be provided with assignment-specific Personal Protective Equipment (e.g. ear protection) and communication equipment.

Further measures to minimise hazards can result from the risk assessment.

# Annex 1

## Information on the execution of risk assessments

### General information

The employer or entrepreneur is obliged to take the necessary occupational safety measures according to the German occupational safety and health act and the accident prevention regulation “Principles of Prevention”. In doing so, he has to take into account all circumstances that can influence the safety and health of the employees at work. The duty to prepare the risk assessment is a core requirement and applies in all sectors of industry, trade and the service sector. The risk assessment also acquires an increasingly higher importance in other statutory requirements, e.g. in the Ordinance on hazardous substances or the Ordinance on industrial safety and health.

It is thus ensured that the company-specific occupational safety and health protection measures are primarily oriented on the actual hazard situation present in the company. By the preventive approach during the preparation of the risk assessment, the employer not only accomplishes his duty of care towards the employees, but also acquires the possibility of positively influencing the economic situation of the company by reducing accident figures and downtimes.

### Operation steps of a risk assessment

The process of preparing a risk assessment includes the identification of all reasonably foreseeable hazards and burdens that can result in connection when carrying out work, the evaluation of these factors (risk assessment), the introduction of measures to minimise hazards and the regular checking of the effectiveness of the measures. Furthermore, documentation on the individual operation steps is to be kept in the company. As the risk assessment is not a static process, regular updates are absolutely essential. A process cycle is created with the goal of organising work as safely as possible.

## First step – System delimitation and form of consideration

In order for a sensible and efficient consideration to be carried out, it is to be decided in a company-specific manner, whether a

- work place-related,
- person-related,
- work area-related or
- activity-related

risk assessment should be carried out. The classical structure of helicopter companies consists of the sectors administration, maintenance (hangar) and flight operation. For the sectors Administration and Maintenance, the work area-related risk assessment makes sense, for the Flight Operation sector the activity-related risk assessment is relevant.

At the same time, a clear delimitation of the scope of work to be reviewed is to be carried out, in order to define the scope of work of the following steps.

## Second step – identifying hazards

A hazard is defined as the possibility of the occurrence of damage or a health impairment. For the identification (recording) of hazards the probability of it occurring or the possible scale of the event is insignificant.

Hazards are thus, for example, characterised by energies and materials coming together with persons in terms of space and time. However, there is also workload stress, or external conditions and requirements that influence the physical and mental state of a person, and must be recognised and taken into account. In practice, plant tours with the OSH Professional and the Occupational Physician, evaluations of accidents, near-misses and illnesses have proven their worth as useful means for recognising the actual situation in the company. The goal of this review is



to systematically record all the possible hazards that the insured individuals could be exposed to during their activity.

**Checklists can give a first overview here.**

**1. Mechanical hazards**

- 1.1 Rotating rotor blade and tail rotor
- 1.2 Oscillating loads and Load Lifting Devices
- 1.3 Breaking loads and falling parts
- 1.4 Lack of sure-footedness/stumbling, slipping
- 1.5 Helicopter crash
- 1.6 Falling from the helicopter and from work places at heights
- 1.7 Moving means of transport

**2. Electrical hazards**

- 2.1 Defective electrical equipment
- 2.2 Electrical overhead power lines

**3. Chemical hazards**

- 3.1 Handling of fuels and lubricants
- 3.2 Handling of plant protection agents
- 3.3 Engine and turbine exhaust gases
- 3.4 Industrial and fire waste gases
- 3.5 Circulating dust

**4. Biological hazards**

- 4.1 Micro organisms
- 4.2 Genetically modified organisms
- 4.3 Allergenic and toxic substances from micro-organisms and similar.

**5. Risk of fire and explosion**

- 5.1 Refueling
- 5.2 Handling of explosives

6. Thermal hazards

- 6.1 Contact with hot media
- 6.2 Contact with cold media

7. Physical hazards

- 7.1 Noise and vibrations
- 7.2 Electrostatic charges
- 7.3 Electromagnetic fields
- 7.4 Radioactive radiation
- 7.5 Downwash
- 7.6 Wind gusts

8. Hazards due to work environment

- 8.1 Heat
- 8.2 Cold
- 8.3 Moisture
- 8.4 Dazzling effect
- 8.5 Circulating dust and snow
- 8.6 Draughts

9. Physical exposure

- 9.1 Moving heavy loads
- 9.2 Walking on steep terrain
- 9.3 One-sided working posture
- 9.4 Stiff physical posture
- 9.5 Wearing Personal Protective Equipment (PPE)

10. Stresses through perceptibility and manageability

- 10.1 Manageability of working materials
- 10.2 Positioning of control devices and indicators

## 11. Psychological distress

- 11.1 Excessive demands
- 11.2 Stress/time pressure/concentration
- 11.3 Short-cycle activity
- 11.4 Irregular working hours
- 11.5 Constantly changing work places
- 11.6 Problems between colleagues

## 12. Hazards through poor work organisation

- 12.1 Incomplete planning and assignment preparation
- 12.2 Incomplete identification of risk factors
- 12.3 Lack of knowledge and ability
- 12.4 Inappropriate working materials
- 12.5 Insufficient inspection obligations
- 12.6 Poor communication
- 12.7 Incomplete rescue chain
- 12.8 Lack of occupational medical prophylaxis
- 12.9 Hazard to third parties and by third parties

## Third step – evaluating hazards

In order to be able to select a suitable occupational safety protective measure for the recognised hazards, a risk evaluation is required. Factors for this are the probability of occurrence and the foreseeable extent of damage relating to each individual hazard.

### Defining factors for the “probability of damage occurring” are:

- duration and frequency of exposure
- probability of a hazardous event occurring
- possibilities of avoiding or limiting damage.

**Annex 1: Information on the execution of risk assessments**

In the case of the extent of damage a differentiation is made between minor injuries or severe, permanent injuries or the death of a person.

The estimation or evaluation of the existing risk can depend in practice essentially on the personal experience and sensitivities of the evaluating person. In order to objectify this subjective process, for example, it makes sense to use a graphic evaluation procedure. The existing risk is allocated to one of 5 categories using a risk graph (of a decision tree).

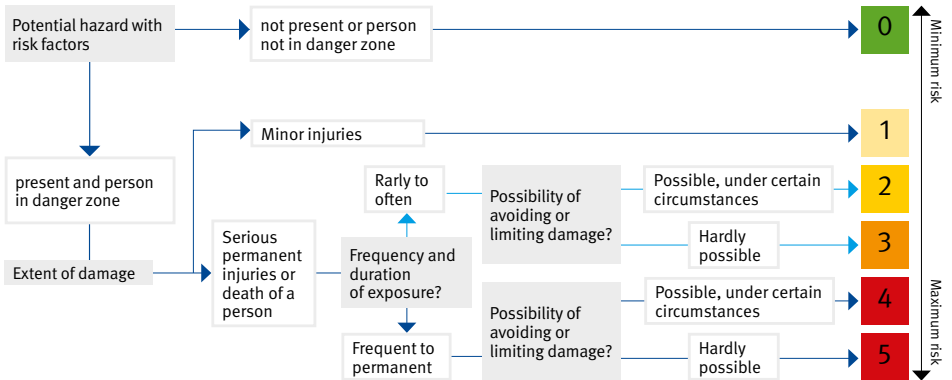

Risks that are evaluated with category 5 represent the greatest possible risk according to the evaluation procedure. In category 0 there is no risk and in category 1 only a slight risk of the probability of damage occurring.

It is defined by the concluding allocation of hazards based on the risk category, whether and to what extent measures to minimise risks or hazards are necessary. In the case of complying with prescribed limit values (e.g. noise), minimum dimensions and distances requirements (e.g. Technical Rules) such an evaluation can be done without.

## Fourth step – specify protective measures

All the necessary work safety protective measures are now to be selected and implemented by the employer in accordance with the risk classification. Economic aspects often take precedence in the selection of measures. Expensive technical investments frequently show long-term economic benefits, as the costs for accidents, occupational illnesses and a high level of sickness-related absences must be incorporated in the calculations.

### General principles for the selection of suitable protective measures:

- The work is to be organised in such a way that a risk for life and health is avoided as far as possible and the remaining risk is kept as low as possible.
- The dangers are to be tackled at their source.
- The state of the art, occupational medicine and hygiene as well as other substantiated findings of occupational research are to be taken into account in the case of the measures.
- The measures are to be planned with the goal of appropriately combining technology, work organisation, other working conditions, social relations and influence of the environment on the work place.
- Individual protective measures are to be treated as subordinate, technical measures have priority.
- Special dangers for groups of employees in particular need of protection are to be taken into account.

(Selection of measures according to sec.4 German occupational safety and health act)

Technical and collectively effective protective measures are much better accepted by the insured individuals as a rule than, for example, wearing elaborate Personal Protective Equipment. At the same time, technical protective measures are not so easy to consciously or unconsciously circumvent. The increase in occupational safety by organisational or personal measures is much lower compared to technical measures.

Solutions are already pointed out in operational practice for a great variety of hazards e.g. in Technical Rules or in the rulebook of the accident insurance companies. If an employer chooses an individual solution variant, he must at least achieve the same safety level and the same health protection.

### **Fifth step – check effectiveness, make changes**

After introducing the occupational safety and health measures it must be identified whether a minimisation of risks was really achieved in the ongoing work process or if the now existing remaining risk is below the limit risk. The possibility exists that by using the protective measures taken, other already existing hazards are intensified or new hazards are created. In such cases, possibly a more suitable solution has to be found and the process of risk assessment restarted (process cycle). There is no specified time window for reviewing the effectiveness of measures taken. It is up to the employer to stipulate an appropriate period.

The risk assessment is to be updated immediately, if significant changes are introduced to the operating processes or other or new activities are started with own hazards.

#### **These are, in particular:**

- the procurement of new working materials
- change of existing flight and work procedures
- handling hazardous goods
- the use of or handling of hazardous substances
- changes in the field of applicable law
- changes in the state of the art
- changes in the field of occupational medical prophylaxis

## Sixth step – necessary documentation

The employer not only uses the documentation of the risk assessment as a separate work instrument, but it also provides the proof to the state authorities and accident insurance companies that he has accomplished his obligations with regard to the implementation of occupational safety and health protection in the company.

With regard to the form of documentation, the legislator only requires that the result of the risk assessment, the stipulated measures and the result of their review (effectiveness check) are discernible from the documents.

It can comprise documents in the form of electronically saved data or in paper form.

### **They must include at least:**

- information on the selected form of consideration
- recognised hazards
- the assessment of the risk
- stipulated occupational safety and health protection measures
- concrete dates for the implementation
- responsible persons
- review of the effectiveness of the measures
- date of updating
- signature of the employer

# Annex 2

## Determining of external load forces

Strongly varying stresses of Load Lifting Devices result from various factors (e.g. oscillating of the load) and flight procedure (e.g. timber logging) in the system of helicopters with external loads. By different accelerations of the helicopter within the scope of aerial work, a dynamic share results in addition to the actual static share of the load. This can briefly assume a 3- to 4-fold value of the static load. The maximum load to be expected results therefore from the static, the dynamic and, in addition, a possible aerodynamic share that can occur based on the negative lift of the load from a specific forward speed. The slinging technology of the load (e.g. tying) also leads to a reduction of the breaking force or carrying capacity of the slinging equipment. Exceeding the carrying capacity or the permanent use of the security area of the Load Lifting Devices can lead to premature wear or to failure. Basis for the dimensioning or the provision of load lifting and slinging equipment by the employer is the reliable determination of the maximum load to be expected.

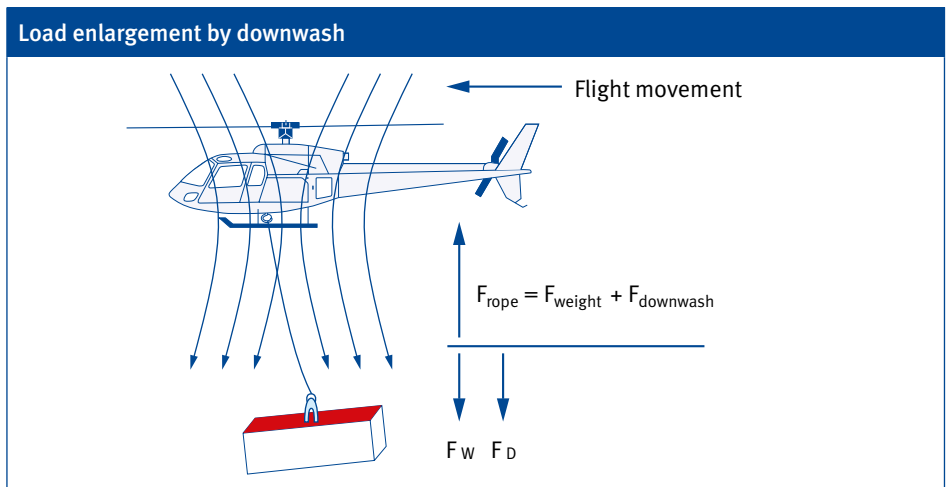

- results through the presence of rotor downwash on the surface (red surface) of the load
- is of significance up to approx. 30 km/h forward speed, after this value, not relevant



- depends greatly on the geometry of the load (e.g. convex or concave surface form)
- can be determined by trials in various suspension heights for various helicopter types

### Load enlarging factor downwash $L_D$

$$L_D = \frac{\text{Load} + (\text{Airflow surface} \times \text{enlarging factor})}{\text{Load}}$$

**Example:** In the case of an airflow surface of  $6 \text{ m}^2$  and an enlargement of  $40 \text{ kg/m}^2$  (AS 332c Super Puma, suspension height 20 m, load 1000 kg) results in an enlarging factor of 1.24 (increase of 24 percent).

### Load enlargement by Forward Speed Drag

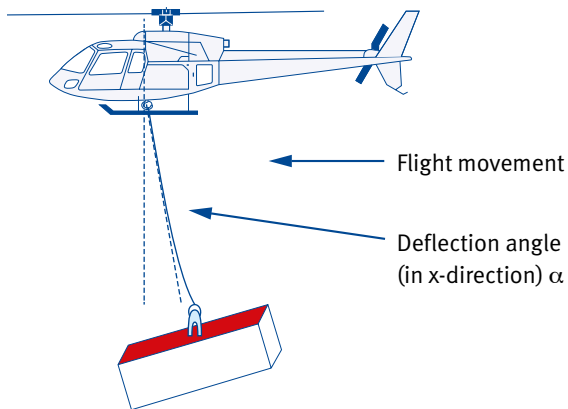

- results through deflection of the load (e.g. through air resistance or through inertia force)
- is calculated through angular relationships (ratio between weight force and deflection)
- plays a subordinate role in the case of normal geometry of the load
- is reduced by the reduction of speed

### Load enlarging factor Forward Speed Drag $L_F$

$$L_F = \frac{\text{Load}}{\text{Load} \times \cos \alpha} = \frac{1}{\cos \alpha}$$

**Example:** In the case of a deflection of  $\alpha = 30^\circ$  in x-direction results due to the angular relationships in a factor of 1.15.

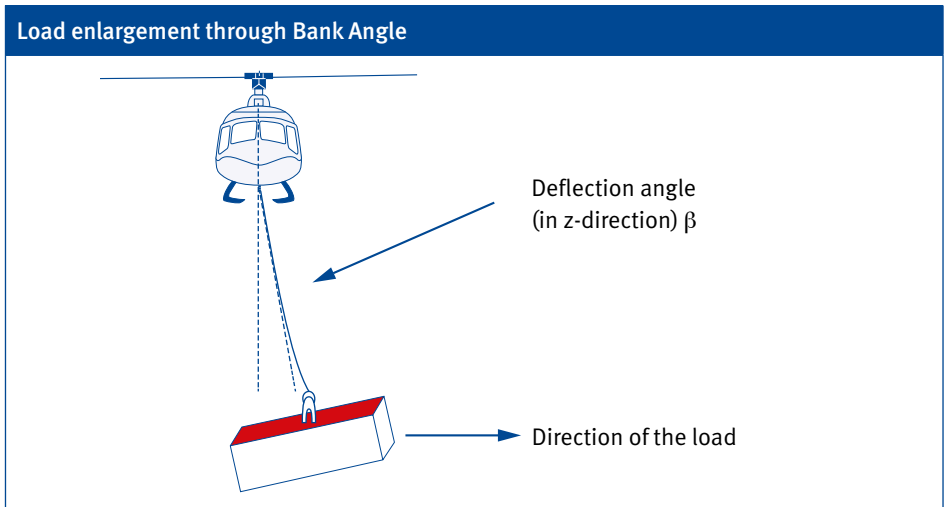

- results by deflection of the load (e.g. through centrifugal force in curves or air resistance)
- is calculated through angular relationships (ratio between weight force and deflection)
- depends on the curve speed
- is determined by the curve radius

### Load enlarging factor Bank Angle $L_B$

$$L_B = \frac{\text{Load}}{\text{Load} \times \cos \beta} = \frac{1}{\cos \beta}$$

**Example:** In the case of a deflection of  $\beta = 40^\circ$  in z-direction results due to the angular relationships in a factor of 1.3.

#### Load enlargement through acceleration of the load

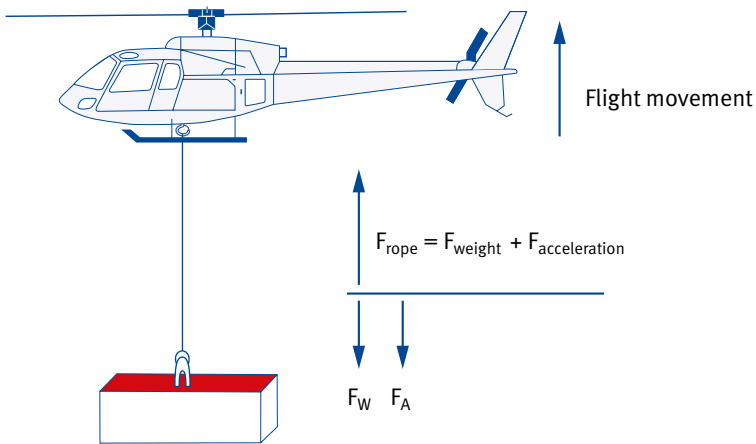

- results through accelerations of the load (e.g. starting load multiple or interception of the helicopter with load)
- is calculated e.g. through inertia law

### Load enlarging factor accelerations $L_A$

$$L_A = \frac{\text{Load} + \text{dynamic share of the load}}{\text{Load}}$$

**Example:** is covered in practice by the so-called “static limit load factor” according to CS-27/29.865.

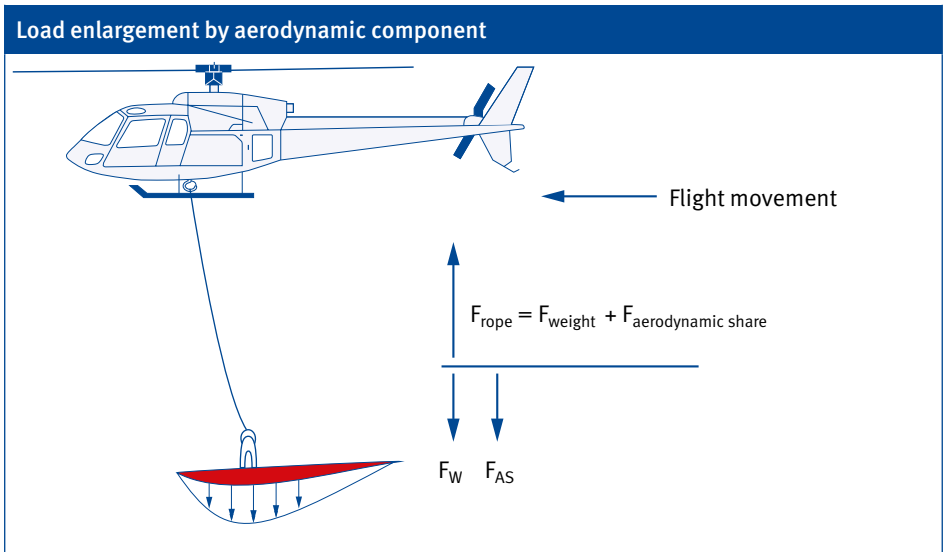

- results through aerodynamic forces on the load (air flow of the load)
- differs greatly depending on the model and version of the load and can only be determined for the individual case
- has as the consequence that the load must be slung at the pressure point

## Load enlarging factor aerodynamic components $L_{AS}$

$$L_{AS} = \frac{\text{Load} + \text{aerodynamic share of the load}}{\text{Load}}$$

**Example:** The factor for the aerodynamic share e.g. of an aircraft as external load (in inverted flight position) can in the case of a forward speed of 70 km/h be 1.8.

## Summary of the factors

The factor of load enlargement is composed of the multiplication of the individual components. It covers the quasi-static stresses by swaying/bank angle and the dynamic stresses (blows) by acceleration peaks. The factor for “Working flight without logging” (Helicopter External Sling Load Operation, HESLO 1, 2, 4 and 5) is 3.0 and for the type of work “Logging” (Helicopter External Sling Load Operation, HESLO 3) based on higher acceleration peaks 3.5.

Special constructions for load lifting require a precise calculation by the manufacturer taking all expected factors into consideration.

# Annex 3

## Attaching of external loads

The Load Lifting Devices (chains, steel and textile ropes, round slings, connection links etc.) available on the market are, as a rule, not dimensioned and coordinated with the special requirements of underload flight operation. Findings that, for example, accelerations occurring in flight operation in the helicopter and external load system can induce significantly higher forces than in the quasi-static crane operation or that the upsurge behaviour of ropes represents a major hazard to the crew, are not or not sufficiently taken into consideration when designing the constructions. It is the employer's task to make suitable Load Lifting Devices (LLD) for the work task available to the employees.

### **The selection and procurement of Load Lifting Devices for flight operation can be made in different ways:**

- A separate dimensioning and selection is carried out for a specific load case and for each deployed Load Lifting Devices. This method makes sense for special loads or when procuring load-related LLD.
- LLD for the general load case (daily working routine) are dimensioned for the maximum expected loads and taking all possible load increasing factors into consideration.

In operational practice the provision of assortments according to weight classes of helicopters (max. external load carrying capacity of the helicopter according to manual) has proved useful for economic and safety reasons. The wrong selection of LLD is minimised by separate storage and targeted use.

At the same time, requirements of the manufacturers of helicopters or cargo hooks are to be observed. It is frequently not possible, for example, to attach multi-leg slings to the primary cargo hook so that intermediate rings (e.g. oval rings) have to be inserted.

The LLD dimensioned and designed for the general load case can be used taking the specific requirements of flight operation into consideration.

## Force-fit and form-fit

In the helicopter sector it corresponds to the rule of technology that loads are attached with positive fit and positive connection. In this way, it is prevented that a load can slip out of the slinging device during the flight by oscillating, rotating or tilting.

The slinging types “wrapped” or “coiled around” are not suitable for helicopter transport. The slinging types “tied” and “double tied” fulfil the requirement according to form-fit and force-fit.

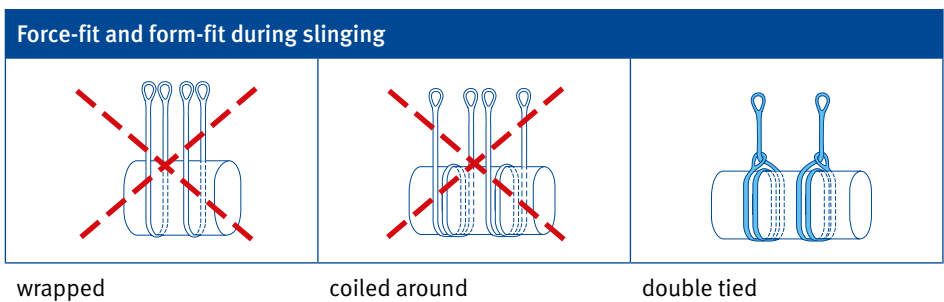

## Multiple leg slinging

In the helicopter sector it is generally the technical rule that multiple leg suspension gears are slung with a suspension link (e.g. oval ring) in a hook. The slinging of 3 or more round slings in one hook is to be avoided.

When using one- or two-leg slinging devices, these are to be dimensioned in such a way that one leg can safely lift the load plus load increasing factors.

### Multiple leg slinging

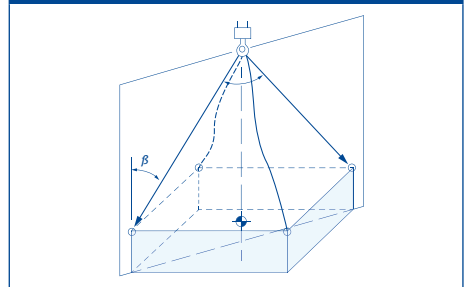

The load attached with four-leg suspension gear, whereby only two legs are load-bearing during

In the case of three- or four-leg suspension gear, a maximum of two carrying legs can be counted on. The reason for this is the dynamics in the flight operation. It is to be assumed that the load does not hang exactly symmetrically, stably and without swinging or turning with the load centre of gravity directly under the load rope.

### Angle of inclination of the slinging devices

In the helicopter sector it is generally the technical rule that the angle of inclination to vertical does not exceed 45°. In the case of an angle of inclination of 60° the complete weight force has the effect in two-leg suspension gear in each leg and the possibility exists that the slinging devices on the loads are drawn together.

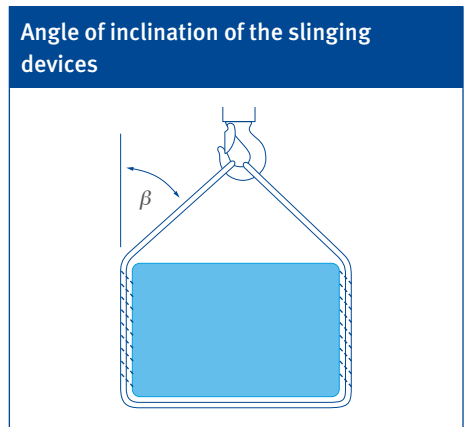

### Dimensioning of cargo hooks

In the helicopter sector it is generally the technical rule that adequately dimensioned cargo hooks, in relationship to the dimensions of the slinging devices, even two legs, can be directly suspended in the hook. The cargo hook must be able to safely lift the load plus load increasing factors (e.g. angle of inclination and swinging of the load). In doing so, the maximum angle of inclination to the vertical angle of 45° and for example the non-overlapping of the lifting belts in the hook must at all costs be complied with.



**Cargo hooks with round slings**

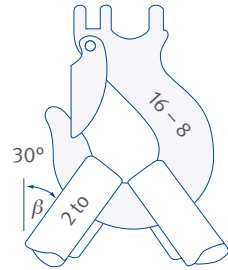
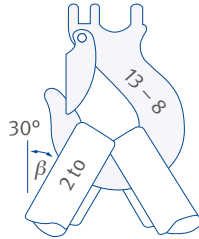
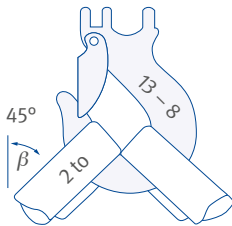

cargo hook dimension 13 – 8 (WLL 5.4 to) in relation to load (>1 to) over-dimensioned, but:

wrap 45° round slings 2 to = hook not optimal to critical overlap

30° round slings 2 to = better, but round slings

30° round slings 2 to, hook dimensions 16–8 = round slings optimally placed

(to corresponds to tonne)

**Cargo hook with lifting belt**

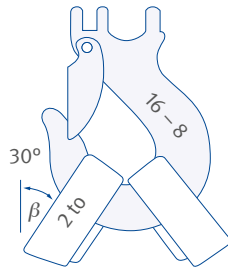
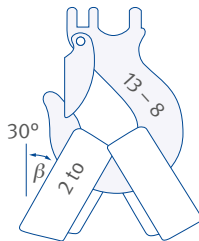
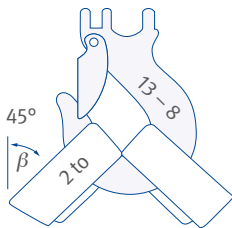

cargo hook dimension 13 – 8 (WLL 5.4 to) in relation to load (>1 to) over-dimensioned, but:

45° lifting belt 2 to = hook position not optimal to critical overlap

30° lifting belt 2 to = better, but lifting belts overlap

30° lifting belt 2 to, hook dimensions 16–8 = lifting belt optimally placed

(to corresponds to tonne)

The maximum carrying capacity is significantly reduced by bent edges or lifting belts that are inserted and overlapped. The transmission of the force in the hook by the lifting belts must take place if possible at the bottom of the hook.

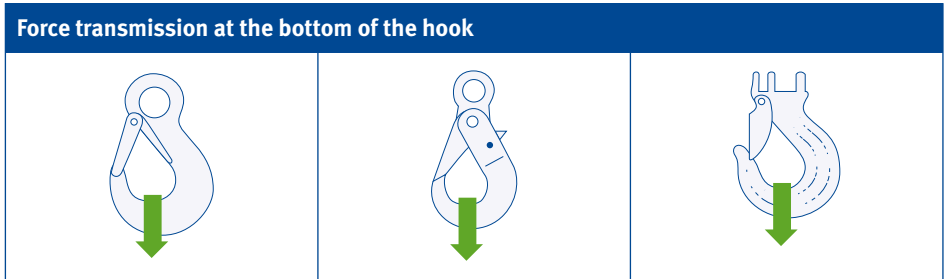

### Length of load lifting and slinging equipment

The safe transport of an external load on the helicopter is mainly determined by the sufficient length of the load lifting and slinging equipment. Hazards for the Marshalls on the ground, the crew and for the environment can be minimised by a sufficient distance of the load from the helicopter or of the helicopter from the ground or structural installations.

The length of the actual load rope must therefore be selected in such a way that the helicopter can hover over the highest obstacle with a clearance reserve of 5 m in the event of forced setting down of the load in case the load touches the ground.

In the case of multiple-leg suspension gear the angle of inclination of the legs and therefore the burden of slinging devices and slinging points is reduced with increasing attaching length. The handling of the load by the Marshalls is also facilitated, as the distance to the pivot point of the load is enlarged.

### Length of load lifting and slinging equipment

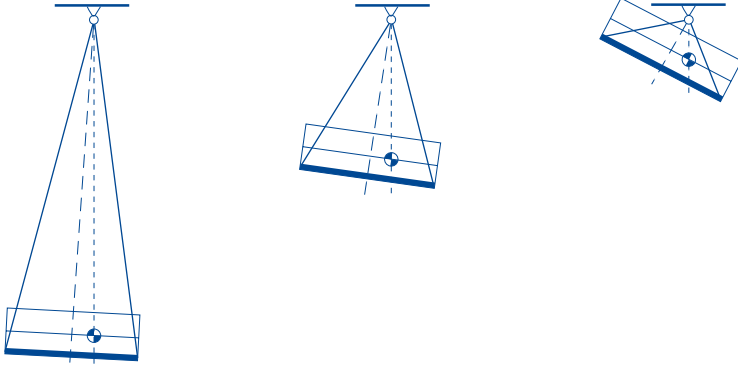

The impacts of downwash on the load or the surroundings also decrease at the same time with increasing distance. A load that is attached with too short a rope further restricts the pilot's possible courses of action, e.g. in the case of a stall.

**As the maximum values of downwash result at a distance of approx. 1.5 times the rotor diameter, loads are not to be positioned there.**

### Load increasing factors by slinging (selection)

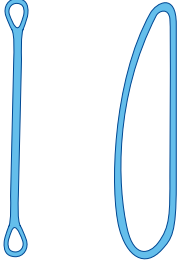
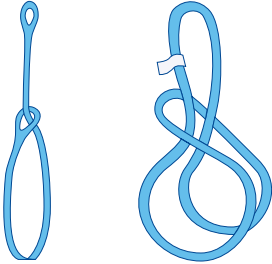
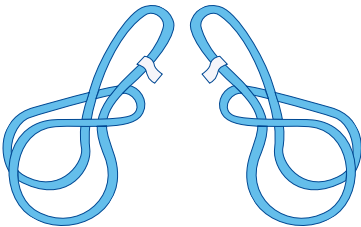
Type of slinging “Direct”	Load of LLD	
	Load Load increase Load increasing factor <b>Overall load</b>	100 % 0 1.0 100 %  Number of legs or units with sufficient carrying capacity Number of load-bearing legs or units Load per leg
<p data-bbox="90 592 573 639">Type of slinging “Tying”</p> 	Load Load increase Load increasing factor <b>Overall load</b>	100 % 20 % 1.2 120 %  Number of legs or units with sufficient carrying capacity Number of load-bearing legs or units Load per leg
<p data-bbox="90 1011 573 1091">Type of slinging + “Tying + angle of Inclination”</p>  <p data-bbox="90 1396 501 1465">assuming that the entire load is carried by one leg</p>	Load Load increase Load increasing factor <b>Overall load</b>	100 % 20 % 1.2 120 %  Number of legs or units with sufficient carrying capacity Number of load-bearing legs or units Load per leg

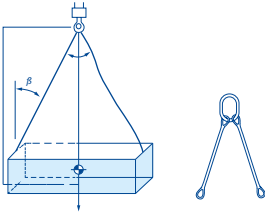
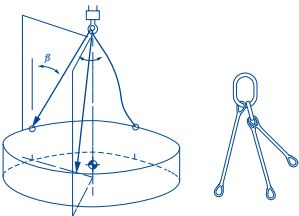
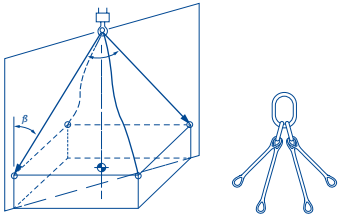
Type of slinging “2-leg suspension gear (TWLS)”	Load of LLD	
 <p data-bbox="101 520 496 579">assuming that the entire load is carried by one leg</p>	<p data-bbox="583 233 941 256">Load 100 %</p> <p data-bbox="583 264 941 288">Load increase 0</p> <p data-bbox="583 296 941 320">Load increasing factor 1.0</p> <p data-bbox="583 328 941 352"><b>Overall load 100 %</b></p> <p data-bbox="583 392 891 480">Number of legs or units with sufficient carrying capacity 2</p> <p data-bbox="583 488 891 512">Number of load-bearing legs or units 1</p> <p data-bbox="583 520 941 544">Load per leg 100 %</p>	
Type of slinging “3-leg suspension gear (THLS)”		
 <p data-bbox="101 943 496 1002">assuming that the entire load is carried by two legs</p>	<p data-bbox="583 655 941 679">Load 100 %</p> <p data-bbox="583 687 941 711">Load increase 41%</p> <p data-bbox="583 719 941 743">Load increasing factor 1.41</p> <p data-bbox="583 751 941 775"><b>Overall load 141 %</b></p> <p data-bbox="583 815 891 903">Number of legs or units with sufficient carrying capacity 3</p> <p data-bbox="583 911 891 935">Number of load-bearing legs or units 2</p> <p data-bbox="583 943 941 967">Load per leg 70.5 %</p>	
Type of slinging “4-leg suspension gear (FLS)”		
 <p data-bbox="101 1398 496 1457">assuming that the entire load is carried by two legs</p>	<p data-bbox="583 1078 941 1102">Load 100 %</p> <p data-bbox="583 1110 941 1134">Load increase 41%</p> <p data-bbox="583 1142 941 1166">Load increasing factor 1.41</p> <p data-bbox="583 1174 941 1198"><b>Overall load 141 %</b></p> <p data-bbox="583 1238 891 1326">Number of legs or units with sufficient carrying capacity 4</p> <p data-bbox="583 1334 891 1358">Number of load-bearing legs or units 2</p> <p data-bbox="583 1366 941 1390">Load per leg 70.5 %</p>	

**Annex 3: Attaching of external loads**

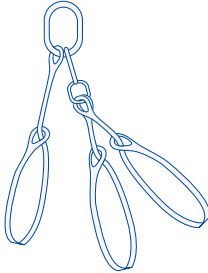
Type of slinging “3-leg suspension gear (THLS) + ties”	Load of LLD	
 <p data-bbox="101 676 496 735">assuming that the entire load is carried by two legs</p>	<p data-bbox="583 387 938 507">                     Load 100 %                      Load increase 70%                      Load increasing factor 1.7  <b>Overall load 170 %</b> </p> <p data-bbox="583 547 893 735">                     Number of legs or units with sufficient carrying capacity 3                      Number of load-bearing legs or units 2                      Load per leg 85 %                 </p>	

**Load increasing factors by slinging (summary)**

Cause	Load increasing factor	Explanation
Straight lift	1.0	applies for angle of inclination in the range 0°–10°
Angle of inclination to vertical	1.41	applies for angle of inclination up to 45 °
Tying of slinging equipments	1.2	does not apply in case of sharp edges and too small radius

## Load increasing factors through flight behaviour

### “Helicopter External Sling Load Operation” (HESLO 1, 2, 4 and 5)

Cause	Load increasing factor	Explanation
Forces by flight procedure (e.g. banking, accelerations)	2.5	static limit load factor
Supplement for sudden jolted accelerations	1.2	based on different measurements
Summary	3.0	

### “Helicopter External Sling Load Operation” (HESLO 3) Logging

Cause	Load increasing factor	Explanation
Forces by flight procedure (e.g. banking, accelerations)	2.5	static limit load factor
Supplement for sudden jolted accelerations	1.4	based on different measurements
Summary	3.5	

The factors listed here only illustrate the load increasing factors based on dynamic influences and reflect the current state of the art.

### Summary load increasing factors for Load Lifting Devices

		“Helicopter External Sling Load Operation” (HESLO 1, 2, 4 and 5), working flight without Logging				“Helicopter External Sling Load Operation” (HESLO 3), Logging	
Load increase by	Material	LLD	SE	3-/4-leg suspension gear		LLD	SE
Flight procedure	Steel textile	3.0	3.0	3.0	3.0	3.5	3.5
Slinging techniques	Steel textile		1.2	1.41	1.7		1.2
Material strengths	Steel textile	1.80	1.80	1.80	1.80	1.80	1.80
		2.62	2.62	2.62	2.62	2.62	2.62
Product							
Individual calculation	Steel textile	5.40	6.48	7.61	9.18	6.30	7.56
		7.86	9.43	11.08	13.36	9.17	11.00
General use	Steel textile	6.48 9.43		9.18 13.36		7.56 11.00	

**Explanations:**

Helicopter External Sling Load Operation (HESLO 3), Logging: A higher strain on LLD results from the work procedure by load peaks than in normal external load flights. These peaks are induced during the load pick-up or load drop-off as a rule. A combination with “bank angle” is therefore not probable.

Flight procedure: Covered by the static limit load factor (according to CS-27/29.865) up to the value of 2.5.

Slinging equipment SE (round slings, chains) is, as a rule, tied and loaded with angle of inclination. As each leg must carry the entire load, it is only calculated with the



slinging technique factor “straight lift with tying”. 3- and 4-leg suspension gear is often used in combination with the slinging techniques “tying” and “angle of inclination”. The factor 13.36 is to be applied here for general use for safety reasons.

Material strengths (material, processing and environmental factors): Depending on the material selection (e.g. textile: polyamide, polyester etc.), special ageing behaviour or type of manufacturing (e.g. pressing or splicing) further additional factors are necessary here.

General use: The LLD provided for the general load case and for the maximum carrying capacity of the helicopter covers every load case in the case of complying with all parameters (also flight operation).

Individual calculation: A calculation for the respective individual case is possible taking all load increasing factors into consideration.

The LLD dimensioned for general lifting gear operation are designed according to Annex I of the Directive 2006/42/EC (Machinery Directive) in the case of metal parts normally with a working coefficient of 4, in the case of wire ropes and their end connections normally with a working coefficient of 5 and in the case of textile fibre ropes or belts normally with a coefficient of 7. In order to determine to what extent these LLDs are suitable for the helicopter assignment with regard to their work load limit, a comparative study is necessary taking into account the working coefficient and the actually existing load increasing factors.

**Comparative study step 1**

Stipulation of maximum external load work load limit of the helicopter according to the manufacturer's specifications.

**Comparative study step 2**

Stipulation of the maximum load of Load Lifting Devices or a component taking into account the load increasing factors (e.g. flight procedure, materials used, slinging technique).

**Comparative study step 3**

Stipulation of the breaking strength of the LLD or component to be assessed.

**Comparative study step 4**

Study of the breaking strength of the LLD in relation to the maximum load of the LLD.

**Comparative study step 5**

Assessment of the suitability of the LLD or of a component with regard to the work load limit during the helicopter external load assignment.

## Application example (steel cable):

Work step	Explanation
<b>Step 1</b> Maximum external load carrying capacity of the helicopter $WLL_{(Hel)} 1400 \text{ kg}$	These details can be found in the documents of the helicopter's manufacturer. As a rule the manufacturer indicates the maximum external load carrying capacity as WLL (Working Load Limit).
<b>Step 2</b> Maximum load of LLD $LOAD_{(max.)} 9072 \text{ kg}$	This value results from the multiplication of the maximum external load carrying capacity of the helicopter with the corresponding load increasing factors (HESLO 1, 2, 4 and 5, general assignment, steel rope as Load Lifting Devices: value 6.48) $1400 \text{ kg} \times 6.48$
<b>Step 3</b> Breaking strength of LLD $BS_{(LLD)} 12500 \text{ kg}$	This value results from the multiplication of the maximum load carrying capacity of the LLD to be assessed (also labelled with WLL directly on the LLD) with the working coefficient for the general lifting gear operation according to the Machinery Directive (see manufacturers' specifications).  $WLL \text{ (steel rope)} \quad 2500 \text{ kg}$ $\text{Working coefficient } 5$ $2500 \text{ kg} \times 5$
<b>Step 4</b> Breaking strength of LLD $BS_{(LLD)} 12500 \text{ kg}$  Maximum load of LLD $LOAD_{(max.)} 9072 \text{ kg}$	$BS_{(LLD)} 12500 \text{ kg} > LOAD_{(max.)} 9072 \text{ kg}$
<b>Step 5</b> The steel rope is to be considered as suitable for the external load assignment with regard to carrying capacity.	Assessment of the suitability of the Load Lifting Devices (here steel rope, WLL 2500 kg) on a helicopter with a maximum external load carrying capacity of 1400 kg.

Example of use (round sling):

Work step	Explanation
<p><b>Step 1</b> Maximum external load carrying capacity of the helicopter WLL<sub>(Hel)</sub> 1400 kg</p>	<p>These details can be found in the documents of the helicopter’s manufacturer. As a rule the manufacturer indicates the maximum external load carrying capacity as WLL (Working Load Limit).</p>
<p><b>Step 2</b> Maximum load of LLD LOAD<sub>(max.)</sub> 13202 kg</p>	<p>This value results from the multiplication of the maximum external load carrying capacity of the helicopter with the corresponding load increasing factors (HESLO 1, 2, 4 and 5, general assignment, round sling as slinging equipment: value 9.43). <math>1400 \text{ kg} \times 9.43</math></p>
<p><b>Step 3</b> Breaking strength of LLD BS<sub>(LLD)</sub> 14000 kg</p>	<p>This value results from the multiplication of the maximum load carrying capacity of the LLD to be assessed (also labelled with WLL directly on the LLD) with the working coefficient for the general lifting gear operation according to the Machinery Directive (see manufacturers’ specifications).</p> <p>WLL (round sling) 2000 kg Working coefficient 7 <math>2000 \text{ kg} \times 7</math></p>
<p><b>Step 4</b> Breaking strength of LLD BS<sub>(LLD)</sub> 14000 kg</p> <p>Maximum load of LLD LOAD<sub>(max.)</sub> 13202 kg</p>	<p><math>BS_{(LLD)} 14000 \text{ kg} &gt; LOAD_{(max.)} 13202 \text{ kg}</math></p>
<p><b>Step 5</b> The round sling slinging device is to be considered as suitable for the external load assignment with regard to carrying capacity.</p>	<p>Assessment of the suitability of the Load Lifting Devices (here round sling, WLL 2000 kg) on a helicopter with a maximum external load carrying capacity of 1400 kg.</p>

### Examples of slinging external loads

FIBC (Big Bag) for helicopter transport

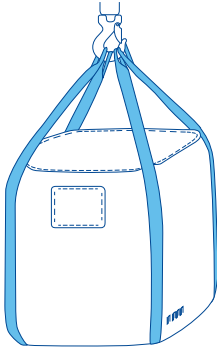

Information:

Select hook size so that all 4 loops with a free leg length of 1 m can be placed next to each other at the bottom of the hook.

In the case of shorter legs the lift must be carried out, for example, with four-leg suspension gear, to guarantee an angle of inclination  $< 45^\circ$ .

It makes sense to indicate the slinging techniques on additional pictograms directly on the FIBC.

### Examples of slinging external loads

Pile of planks with several loose piles standing next to each other

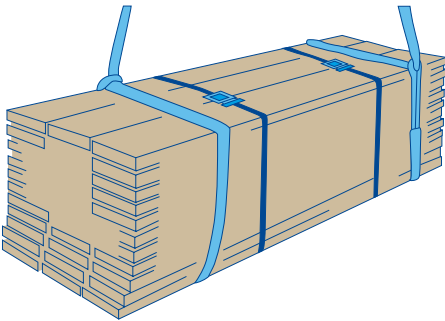

Information:

Sawn planks tied with lashing straps to a "load unit". A round sling attached respectively right and left with coiling around (form-fit and force-fit).

Slinging technique can only be used in the case of additional secured piles (load units).

Due to the possibility of the load being able to twist there is a tendency to rotate or see-saw.

Edge protectors prevent damage to round slings.

Examples of slinging external loads

Pile of planks with several loose piles standing next to each other

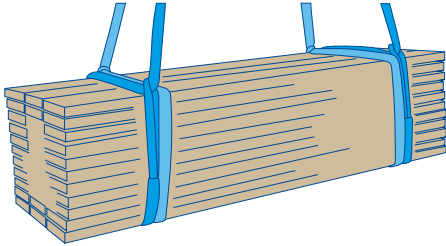

Information:

Sawn planks without further lashing straps attached respectively on the right and left with two round slings and coiling around as a stable load (form-fit and force-fit). Slinging only with equal length round slings possible. Edge protectors prevent damage to round slings.

Pile of planks with several loose piles standing next to each other

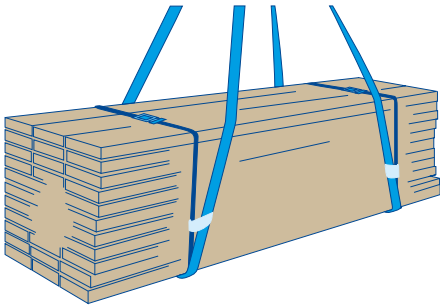

Information:

Sawn planks tied with lashing straps to a “load unit”. A lifting belt wrapped on the right and the left respectively and secured against slipping (stable load). This slinging technique is only possible in the case of additional secured piles (load units). Edge protectors prevent damage to lifting belts and lashing straps. Lashing and slinging equipment can be used as one unit.

### Examples of slinging external loads

#### Logs of wood

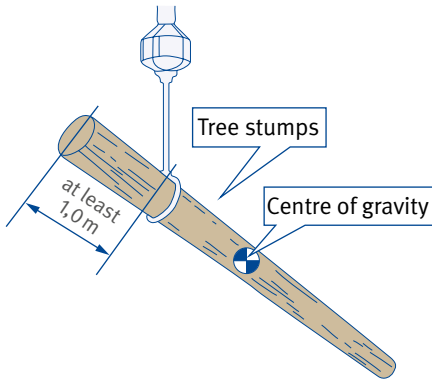

#### Information:

The slinging point must be selected at least 1 m from the front and at the thicker end of the log.

The centre of gravity may not be chosen as attachment point, as the log can tend to twist and rotate during the flight.

#### Pipes with a smooth surface

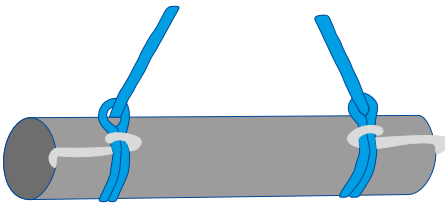

#### Information:

The possibility exists, when attaching such pipes or materials, that the slinging device shifts to the centre during the flight and the load therefore becomes unstable. An additional fixing measure is therefore necessary. In order to reach a defined flight position in the case of forward speed, the use of special air deflectors (e.g. brake parachute) is possible on the external load.

Inappropriate Load Lifting Devices and slinging techniques	
Clamping and vacuum lifters	no form-fit and force-fit
Spreaders for bore holes and hollow parts	no form-fit and force-fit, in the event of a momentary unloading the load can be lost
Forks (crane forks)	no form-fit and force-fit
Hooks without safety catch	no form-fit and force-fit
No low-torque ropes as Load Lifting Devices	rotate under load
Belts, shapeless webs with loose covers	flying up in flight operation, vibrating and banging
Constructions with sharp, narrow thimbles	tips can bend, danger of getting caught
Rope cast heads	too massive (too big), connection is hard to secure
Eddy rotational hooks as swivels on load ropes	are not made for permanent load
Eddy rotational hooks without ball bearings as slinging equipment	rotate when not under load
Multiple leg suspension gear without corresponding ring or slinging equipment divided by cargo hooks	position of the legs not clear, load destabilised, suspension in primary cargo hook not possible safely, slinging equipment can slip through
Steel rope without thimbles	steel loops can twist, damage of the rope to be expected
Textile ropes without thimbles	damage of the rope by friction in a very short time
Type of slinging wrapped or coiled around	no form-fit and force-fit
Tying with loose strands	round slings can be destroyed, for example, by friction heat during tightening,
Slipping of slinging devices over each other	destruction possible by friction heat



# Annex 4

## Instructions and briefings

### Instructions

In order to ensure the safety and health of the employees during all activities in the company, and if possible to improve these, employees must be regularly instructed in safety. As well as this legal obligation, there are however further reasons that make regular and comprehensible training sessions necessary.

#### **These are, among others:**

- Instructions help to avoid accidents and therefore to avert suffering for the employees involved and unnecessary costs for the company.
- The employees recognise that the employer cares about safety at work.
- A trouble-free work procedure is made possible.

The goal of instructions is to ensure safe work. This is not possible without knowledge of the risks and necessary safety measures. The necessary knowledge, capabilities and also wishes do not result by themselves, it has to be conveyed.

### When must employees be instructed?

- initial instruction before starting the activity or in case of taking on a new task, comprehensive instruction on all occurring hazards, burdens and their averting
- regular repetitions at least once a year
- depending on the type and extent of hazards and burdens more frequently than yearly
- after specific incidents and serious accidents
- in case of specific activities (e.g. assignment in noise sectors)
- when handling hazardous substances
- in case of ascertained unfavourable safety or health behaviour

## Who must instruct?

The employer or other superiors from the company are obliged to do so. If necessary, further persons (e.g. Heads of Operations) can be involved.

Basically, there is also the possibility of using electronic media as tools within the scope of instructions. It should be observed here that the instruction contents are made available individually and specifically for each work place. The possibility must exist at all times that the insured individual can contact an instructing person. A comprehension test should take place after completion of the instruction with electronic tools.

### Planning and execution of the instruction:

- set instruction goals (selection of topics)
- compile information material (e.g. training cards)
- stipulate the duration of the training (max. one hour)
- specify the size of the group (max. 8 persons in case of practical exercises)
- stipulate the time window (the attentiveness of participants is higher in the morning than in the afternoon)
- select the location of the event (possibly also directly at the work place)
- observe the state of knowledge of all participants (demands not too high or too low)
- stipulate training date and announce it in good time
- involve participants (active participation, questions and discussions)
- carry out practical exercises (inform and instruct)
- summarise contents of the training
- prepare documentation
- check the success of the training

## Briefings

There are always several persons at different locations taking part in assignments with helicopters. It is important to ensure that all participants not only know their work task but are also informed about the whole procedure of the assignment. At the same time, assignment-specific safety options are indispensable, so that it is possible to act safely and in a coordinated manner in critical situations. A briefing before the assignment is therefore imperative.

## Contents of the briefing



The briefing is carried out immediately before the assignment starts. It should be carried out basically by the Head of Operations or helicopter pilot with the participation of an experienced Marshaller.

The briefing does not constitute the actual education or work training of the employees. This must already take place at a much earlier stage in the company.

**It should:**

- give orientation and an overview of the present work task and situation (circumstances, conditions and particularities)
- give information on the concrete work execution (spatial configuration and procedure)
- enable coordination of the various procedures (among others at the load pick-up point and load drop-off point)
- serve to issue clear directions
- serve to remind about already agreed fundamental safety measures and rules of conduct
- enable special, necessary arrangements for the individual assignment

**Topic selection for the operational briefing using the example of “wood logging”**

**What does the assignment contain?**

- amount of wood and type of wood, assortment
- possible weights of the merchandise to be transported
- state of the wood and degree of dryness
- \_\_\_\_\_

**Where is the assignment flown/completed?**

- outside working station: approach, landing spot, refueling place, type of refueling, available working materials, car parking situation, material, Load Lifting Devices and slinging equipments, retreat area for third parties, emergency landing places, danger signals, traffic and access regulations
- load pick-up site: position of logging, environmental conditions, possible accesses for persons, danger zones, start of work and work direction, approach direction, take-off direction, security area for Marshallers, site for emergency jettisoning

- load drop-off site: approach direction, load drop-off site and direction, security area for Marshallers, turning area, slinging equipment depot
- flight path: flight obstacles, alternative routes, risks for/ due to the surroundings, necessary safety measures

- \_\_\_\_\_

### **Who flies the command?**

- participants: names and phone numbers, positions, tasks, competences, duties, who does what and how, group formation, collaboration with external companies, coordination of work

- \_\_\_\_\_

### **How is the order carried out?**

- work organisation, concrete work procedure, load collectives, slinging techniques, number of rotations, fuel stops, breaks, catering, communication, radio communication, commands, hand signals

- \_\_\_\_\_

### **When is the order carried out?**

- expected duration, planned start and finish of the order, timing, rotation times, weather development

- \_\_\_\_\_

### **Special measures during implementation?**

- accident risks, special safety measures, Personal Protective Equipment, behaviour around the helicopter, tidiness, work discipline, radio discipline, emergencies, first aid measures, first aid workers, first aid material

- \_\_\_\_\_

## After the assignment – debriefing

An important component of the flight or order follow-up is the debriefing. Debriefing can take up a significant share of the time in the case of complex assignments.

Both positive and negative findings as well as procedures during the completed assignment should be discussed and evaluated here. The goal is to make safe procedures reproducible and to analyse problems, uncertainties and hazards that have occurred. After recognising the causes, suggestions for improvement and measures to increase safety for the following orders must be stipulated (risk assessment principle).

# Annex 5

## Means of communication

Communication is “part of safety” during all operations with helicopters. For this reason, the standardisation of signs, words and instructions and the sensible use of technical aids are of great safety importance.

### Handling radio equipment

The radio device or combination of radio device and protective helmet with intercom form the basis of verbal communication during the helicopter assignment. Each employee taking part must be able to operate a radio device to transmit exclusively necessary and important messages to those taking part in the assignment. It is imperative that a functional check is carried out before the respective assignment, for the employee is responsible for the operational readiness of the radio device following the takeover.

#### It must:

- be treated carefully
- be used in suitable protective sleeves
- be used in vertical position, as the power output of the antenna is lowest in direct extension of the antenna
- be used in special carrying bags and secured against falling out
- be protected against strong vibrations and blows
- be protected against intensive contact with water, snow and moisture
- be kept ready for use, i.e. the batteries or the radio devices are to be recharged with special chargers after the end of the activities
- be ensured that defective devices are replaced

Commands via radio must be unambiguous, in chronological order and spoken clearly and distinctly. It should be spoken into in a normal tone of voice, not too loud.

**Annex 5: Means of communication**

<b>Command</b>	<b>Meaning</b>
Down	Helicopter descends
Up	Helicopter climbs
Altitude 3, 2, 1	Indication of position in metres, e.g. distance load–ground
Hold	Helicopter maintains height and position
Right/left	Helicopter hovers to the right/left from the pilot’s point of view
Proceed forward/back	Helicopter hovers forward/back from the pilot’s point of view
Direction 11 o’clock	Helicopter hovers towards indicated direction from the pilot’s point of view
Contact	Marshaller seizes lifting hook at shoulder level/load touches ground
Attached	Slinging device is attached to the hook
Rope tightened	Load Lifting Device/load rope tightened/under load
Detached	Slinging device is detached from the cargo hook
Disconnected	Slinging device is disconnected from the load
Clear	No obstacles in flight path
Stop stop	Break off of current operation, awaiting further instructions

The listed commands are to be used for general transport and assemblies. They represent a selection taken from practical experience and can be adapted to the internal company needs in the enterprise.



Flight direction details are given in metres and in the order of sequence:  
 “Flight direction – distance in metres” clockwise from the pilot’s point of view.

Command	Meaning
1	Distance indications in metres
Up/down 1	Direction indication with distance
Direction 1 o’clock 10	Direction indication with distance with shift by clock-reference direction

#### Clock-reference direction from the pilot’s point of view

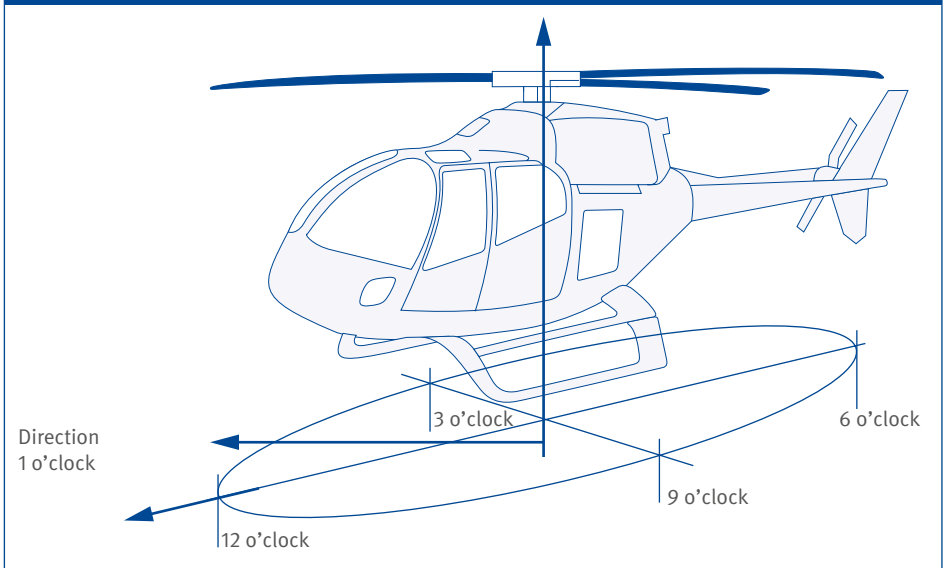

**Annex 5: Means of communication**

In order to call a helicopter or a station directly, for example, the internationally valid ICAO radio alphabet is used.

A	ALFA	(ælfɑ)	I	INDIA	(indi.ɑ)
B	BRAVO	(brɑ:ˈvɒ)	J	JULIET	(dʒu:li.ˈet)
C	CHARLIE	(tʃɑ:li)	K	KILO	(ki:lo)
D	DELTA	(deltɑ)	L	LIMA	(li:mɑ)
E	ECHO	(eko)	M	MIKE	(mɑik)
F	FOXTROT	(fɒkstrɒt)	N	NOVEMBER	(nɒˈvembə)
G	GOLF	(gɒlf)	O	OSCAR	(ɔskɑ)
H	HOTEL	(ho:ˈtel)	P	PAPA	(pəˈpɑ)
Q	QUEBEC	(keˈbek)	V	VICTOR	(viktɑ)
R	ROMEO	(ro.mi.o)	W	WHISKEY	(wiski)
S	SIERRA	(siˈerɑ)	X	X-RAY	(eksˈrei)
T	TANGO	(tæŋgo)	Y	YANKEE	(jæŋki)
U	UNIFORM	(ju:nifɔ:m)	Z	ZULU	(zu:lu:)

1	ONE	(wən)	6	SIX	(siks)
2	TWO	(tu:)	7	SEVEN	(se-vən)
3	THREE	(θrē)	8	EIGHT	(āt)
4	FOUR	(fōr)	9	NINE	(nīn)
5	FIVE	(fīv)	0	ZERO	(zir-(.)ō)

International ICAO spelling table with phonetic reproduction

**Example for calling a helicopter:**

**D-HEGF** “Delta-Hotel Echo Golf Foxtrot” usually: “Golf Foxtrot”

**Example for calling out numbers:**

**20** “Two Zero”      **85** “Eight Five”

All figures are transmitted by articulating all individual figures, whole hundreds or thousands in generally common pronunciation.

The employer shall endeavour to ensure that special working radio devices can be used for HESLO, induced by disturbances on the aircraft radio by third parties.

## **Marshalling helicopters by hand signs**

Marshalling a helicopter means that the pilot is marshalled by a suitable person on the ground with clear hand movements that must be defined and known beforehand.

Marshalling is necessary if there is not sufficient space for safe solo landing or the pilot cannot safely estimate the lateral distances to the surrounding setting.

A very uneven landing ground can also make it necessary.

**Rules for marshalling helicopters:**

- If possible, establish radio communication with the pilot or the crew.
- Marshalling is carried out from the helicopter’s point of view against the wind, i.e. the Marshaller must have the wind behind him and face the landing area.
- Visual contact with the helicopter and later eye contact with the pilot is to be established.
- The landing site is to continue to be observed during the landing process.
- It is imperative that the Marshaller maintains his position during the landing process even in the case of strong downwash or driving snow.
- If necessary, a kneeling position is to be assumed.

- In case of critical situations or in cases of doubt, the landing should be forgone or the manoeuvre aborted.
- When necessary, instructions to fly off must be given.

Optimum landing site conditions are present, if the direct landing site is level and has a square surface with an edge length of 12 to 20 m, depending on the size of the helicopter. The obstacle-free landing area should thereby have a diameter of 100 metres.





**Points to assess the landing site:**

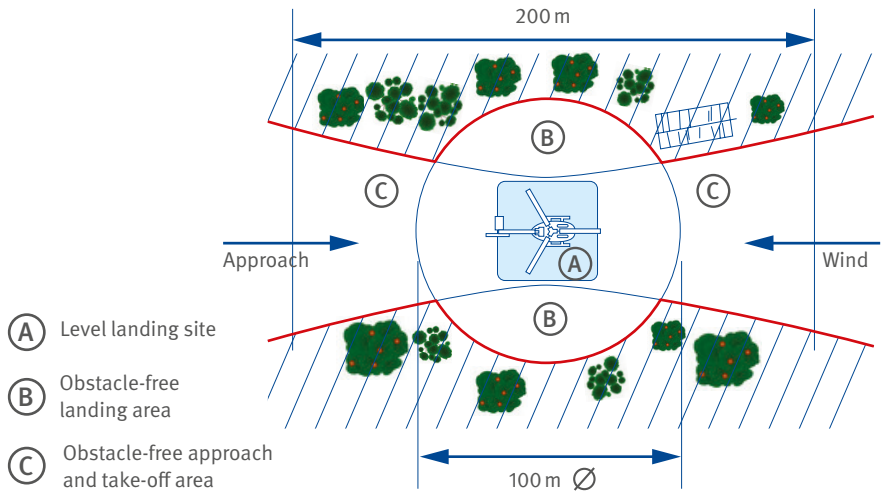



- clarification of real estate (consent)
- existing flight obstacles (buildings, trees, masts, overhead power lines, ropes, poles and fences)
- necessary protection of the surroundings (structural installations traffic routes and natural vegetation)
- level landing site (necessary size)
- terrain as level as possible, flat direct landing site without hollows
- stability of the ground at the direct landing site (e.g. snow)
- possibilities of stirring up loose ground (not natural ground, sand and gravel)
- necessity of moistening the ground to avoid dust development
- space for main and tail rotor
- presence of loose objects (boards, tarpaulins, sheets of metal, equipment, belts or vegetation)
- possibility of access and traffic regulations
- animals in the surroundings, even within fences and stables
- possible wind directions and wind speeds

## Landing site design

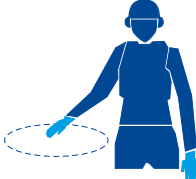

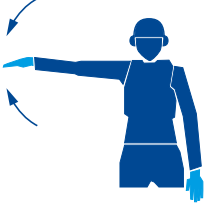
### Selection of signs for marshalling the helicopter

Meaning	Description	Illustration
<p>Attention At beginning Use caution</p>	<p>Hold up right arm. Palm of the hand faces forward</p>	
<p>Stop Interruption Do not continue to execute movement</p>	<p>Extend both arms sideways vertically, palms of the hands face forward</p>	
<p>Stop – Danger</p>	<p>Extend both arms sideways horizontally, palms of the hands face forward and bend and extend arms alternately</p>	
<p>Lift Up</p>	<p>Hold up right arm, palm of the hand faces forward and makes slow, circular movement</p>	
<p>Sink Down</p>	<p>Hold down right arm, palm of the hand faces inward and makes slow, circular movement</p>	

Meaning	Description	Illustration
Slowly	Extend right arm horizontally, palm of hand faces down and is moved up and down slowly	
Taking off	Keep right arm up, palm of the hand faces forward and move arm sideways to and from	
Come forward	Bend both arms, palm of the hand faces inwards and beckon with the underarm	
Go back	Bend both arms, palm of the hand faces outwards and beckon off with the underarm	

# Annex 6

## Information on setting up outside working stations

### 1 General information

The employer must take all the necessary measures to set up suitable outside working stations according to the type of use and the spatial possibilities. Coordination measures for spatial division, timing and maintenance of all safety measures are to be regulated in good time and comprehensively. Using the example of the type of operation “wood logging” basic requirements are illustrated below.

### 2 Outside working station

**Necessary spatial division for the safe operation of an outside working station:**

- load drop-off site
- sufficiently stable road for vehicles
- approach area, turning area, take-off area for the helicopter
- security zone for ground personnel in case of danger
- area for storing necessary slinging equipments
- helicopter landing site with refuelling and service station
- fuel storage area
- if present, workshop and store for air traffic material
- parking area for vehicles
- stopover zone for uninvolved third parties

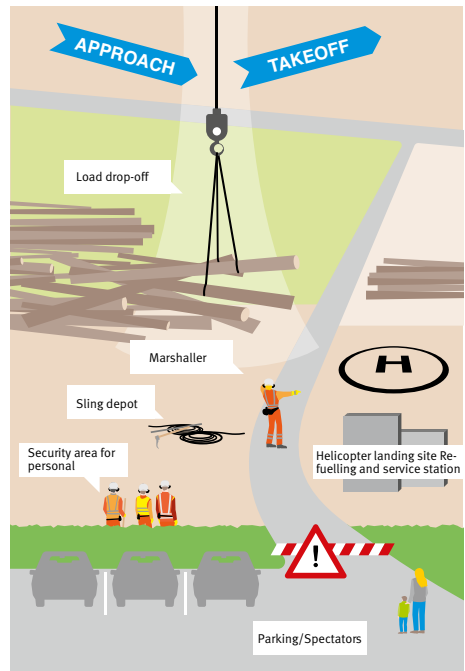



**General safety rules:**

- In the spatially divided areas (e.g. load pick-up or drop-off site) only those persons are to stay that are immediately involved in the transport process.
- Third parties must stay outside the necessary barriers in a safe area or room.
- If necessary, safety lookouts are to be deployed to actively enforce the safety measures.
- Objects, external loads to be lifted or loose vegetation that could be stirred up by the rotor downwash, must be secured or removed.
- Vehicles are only to be parked on allocated parking spaces.
- Open fires or open flames are to be forbidden.

**2.1 Outside working station – conduct at the load pick-up site**

The process of load lifting can become necessary in extremely difficult terrain. This includes, in particular, steep terrain, slippery ground, stony places and all types of obstacles. But further hazards such as noise or the stirring up of dust become effective even during the actual activity. This working environment requires unconditional compliance with rules of conduct.

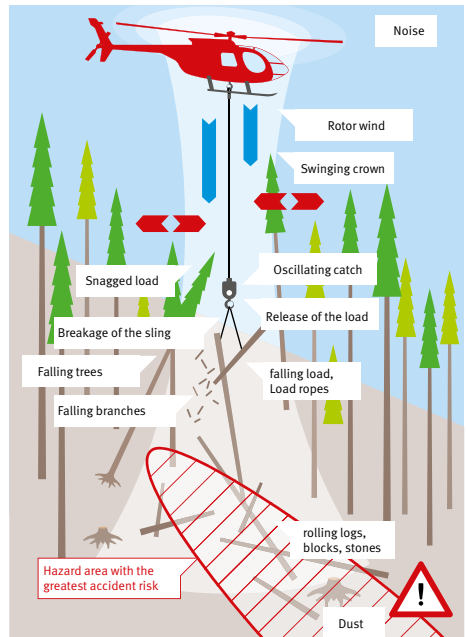

**General rules of conduct:**

- constantly record hazards that arise from the working environment (terrain, ground cover, tree population, falling objects) and coordinate behaviour accordingly
- wear Personal Protective Equipment/conspicuous working clothes
- actively keep third parties away

**Before the approach of the helicopter:**

- identify, think through and determine the work procedure before the helicopter approaches
- identify and stipulate security area and escape routes depending on the approach to be expected
- take a firm and safe standing point
- complete preparatory work, in particular, the attaching of slings to the load

**During helicopter approach:**

- direct gaze in the direction of the helicopter or the canopy of standing trees
- above all, observe and safely grasp cargo hooks and empty slings that are in the cargo hook
- pay attention to falling branches or stirred up objects
- let the cargo hook moving at great speed touch down on the ground first and then grasp securely

**After attaching the load:**

- Go to the security area immediately, never stay underneath the load.
- Always move to safety diagonally to the slope or uphill – never downhill. The retraction path or escape path must be in the opposite direction to the load movement and the take-off direction of the helicopter.
- All persons must go to the same security area and may not leave in different directions.

### Hoisting the load and flying off:

- The command to lift the load may only be given, if nobody can be endangered by the hoisting of the load.
- The danger zone and the load are to be observed from lifting the load to flying off. Attention should be paid especially to falling objects (branches, crown pieces, trees falling over, load parts).
- In particular, attention must be paid to the intended and proper fit of the slings.
- If necessary, a clear command to stop the hoist is to be given.
- Work may only be continued, if flying off has taken place.

## 2.2 Outside working station – conduct at the load drop-off site

The same rules of conduct apply for the load drop-off site as for the load pick-up site.

Prerequisite for safe work is a sufficiently large and appropriate storage area. In this way, it is avoided that unnecessarily high or confusing flight polders arise. If necessary, several load drop-off sites are to be stipulated.

In order to ensure eye contact between the pilot and the Marshall on the ground, the security area and the storage area of the slinging equipments should be laid out on the pilot side of the helicopter. The escape route to the security area must always be kept clear.



# 7 References

The following references are indicated in the chapters and annexes mentioned here:

Chapter/Annex	Reference	Title
Chapter 1	(EU) No 965/2012	Commission Regulation
Chapter 2.1	(EU) No 965/2012, Article 2, (7) EASA ED Decision 2014/018/R, Annex VIII, Part-SPO, AMC1/GM1 SPO. SPEC.HESLO.100	Definitions Acceptable Means of Compliance (AMC) and Guidance Material (GM) to Part-SPO
Chapter 2.2	Guideline 2006/42/EC and Ninth Regulation on Product Safety Act (Machinery Regulation – 9 <sup>th</sup> Product Safety Regulation (ProdSV))	Machinery Guideline
Chapter 2.3	Guideline 2006/42/EC and Ninth Regulation on Product Safety Act (Machinery Regulation – 9 <sup>th</sup> Product Safety Regulation (ProdSV))	Machinery Guideline
Chapter 2.7	EASA CS 27 or 29.865 et seq., EASA CM-CS-005	Certification Specifications for Small Rotorcraft, Certification Specifications for Large Rotorcraft, Certification Memorandum PCDS
Chapter 2.8	EASA ED Decision 2014/018/R, Annex VIII, Part-SPO, AMC1 SPO.SPEC. HEC.100(c)(1)	Acceptable Means of Compliance (AMC)
Chapter 3.5	EASA ED Decision 2014/018/R, Annex VIII, Part-SPO, AMC1 SPO.SPEC.HEC.100 et seq., e.g.: On board: (d)(1)(ii) On the ground: (e) Training: (e)(1)(i)	Acceptable Means of Compliance (AMC)

Chapter/Annex	Reference	Title
Chapter 4.2	EASA ED Decision 2014/018/R, Annex VIII, Part-SPO, AMC1/GM1 SPO. SPEC. HESLO.100(c)(3)  EASA ED Decision 2014/018/R, Annex VIII, Part-SPO, AMC1 SPO.SPEC. HEC.100(c)(3)	Acceptable Means of Compliance (AMC) and Guidance Material (GM) to Part-SPO
Chapter 4.3.1	Guideline 2006/42/EC and Ninth Regulation on Product Safety Act (Machinery Regulation – 9 <sup>th</sup> Product Safety Regulation (ProdSV))	Machinery Guideline
Chapter 4.3.7	EASA CS 27 or 29.865 et seq., EASA CM-CS-005	Certification Specifications for Small Rotorcraft, Certification Specifications for Large Rotorcraft, Certification Memorandum PCDS
Chapter 6.1.1	IATA DG	IATA Dangerous Goods Regulations
Chapter 6.3	EASA ED Decision 2014/018/R, Annex VIII, Part-SPO, AMC1/GM1 SPO. SPEC. HESLO.100(c)(1)  EASA ED Decision 2014/018/R, Annex VIII, Part-SPO, AMC1/GM1 SPO. SPEC. HESLO.100(c)(2)  EASA ED Decision 2014/018/R, Annex VIII, Part-SPO, AMC1/GM1 SPO. SPEC. HESLO.100(c)(3)  EASA ED Decision 2014/018/R, Annex VIII, Part-SPO, AMC1/GM1 SPO. SPEC. HESLO.100(e)	Acceptable Means of Compliance (AMC) and Guidance Material (GM) to Part-SPO

## References

Chapter/Annex	Reference	Title
Annex III	EASA ED Decision 2014/018/R, Annex VIII, Part-SPO, AMC1/GM1 SPO. SPEC. HESLO.100(c)(2)	Acceptable Means of Compliance (AMC) and Guidance Material (GM) to Part-SPO
Annex V	EASA ED Decision 2014/018/R, Annex VIII, Part-SPO, AMC1/GM1 SPO. SPEC. HESLO.100(c)(5)	Acceptable Means of Compliance (AMC) and Guidance Material (GM) to Part-SPO



## BG Verkehr

Ottenser Hauptstraße 54  
22765 Hamburg  
Tel.: +49 40 3980-0  
Fax: +49 40 3980-1999  
E-Mail: [praevention@bg-verkehr.de](mailto:praevention@bg-verkehr.de)  
Internet: [www.bg-verkehr.de](http://www.bg-verkehr.de)